

Name _____

Date _____

- Shade the first 7 units of the tape diagram. Count by tenths to label the number line using a fraction and a decimal for each point. Circle the decimal that represents the shaded part.

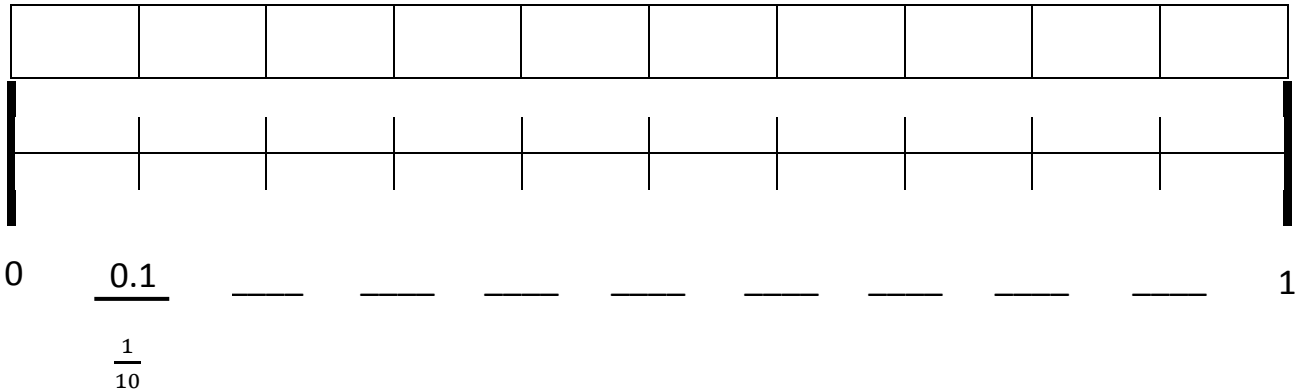

- Write the total amount of water in fraction form and decimal form. Shade the last bottle to show the correct amount.

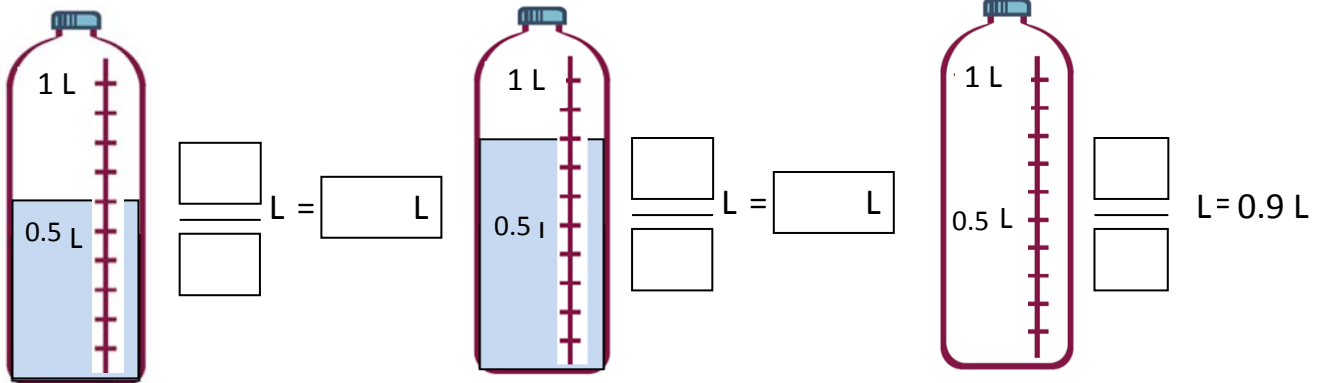

- Write the total weight of the food on each scale in fraction form or decimal form.

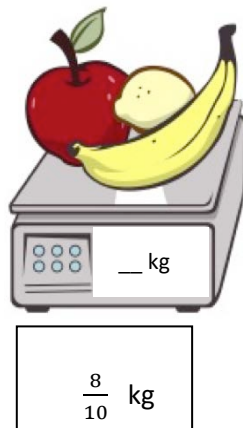
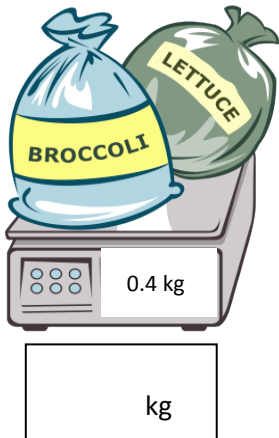

4. Write the length of the bug in centimeters. (Drawing is not to scale.)



Fraction form: _____ cm

Decimal form: _____ cm

How far does the bug need to walk before its nose is at the 1 cm mark? _____ cm

5. Fill in the blank to make the sentence true in both fraction form and decimal form.

a. $\frac{8}{10}$ cm + _____ cm = 1 cm

0.8 cm + _____ cm = 1.0 cm

b. $\frac{2}{10}$ cm + _____ cm = 1 cm

0.2 cm + _____ cm = 1.0 cm

c. $\frac{6}{10}$ cm + _____ cm = 1 cm

0.6 cm + _____ cm = 1.0 cm

6. Match each amount expressed in unit form to its equivalent fraction and decimal forms.

3 tenths	$\frac{5}{10}$	0.2
5 tenths	$\frac{9}{10}$	0.6
6 tenths	$\frac{2}{10}$	0.3
9 tenths	$\frac{3}{10}$	0.5
2 tenths	$\frac{6}{10}$	0.9

Hand-drawn lines connect '3 tenths' to $\frac{3}{10}$ and $\frac{3}{10}$ to 0.3.

Name _____

Date _____

1. For each length given below, draw a line segment to match. Express each measurement as an equivalent mixed number.

a. 2.6 cm

b. 3.4 cm

c. 3.7 cm

d. 4.2 cm

e. 2.5 cm

2. Write the following as equivalent decimals. Then, model and rename the number as shown below.

a. 2 ones and 6 tenths = _____

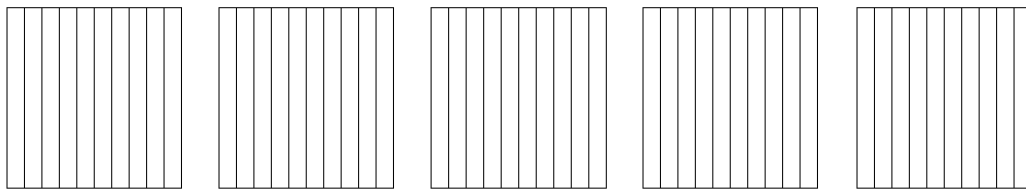

$$2\frac{6}{10} = 2 + \frac{6}{10} = 2 + 0.6 = 2.6$$

b. 4 ones and 2 tenths = _____

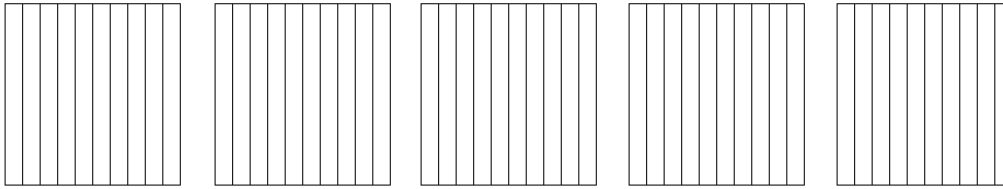

c. $3\frac{4}{10}$ = _____

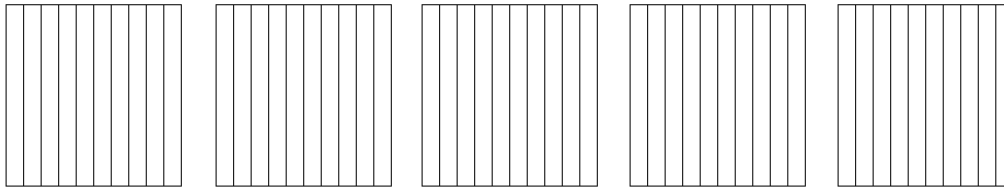

d. $2\frac{5}{10}$ = _____

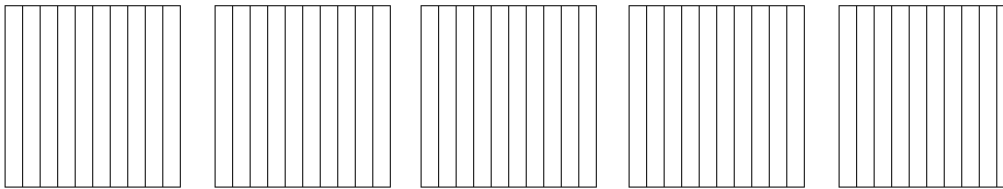

How much more is needed to get to 5? _____

e. $\frac{37}{10}$ = _____

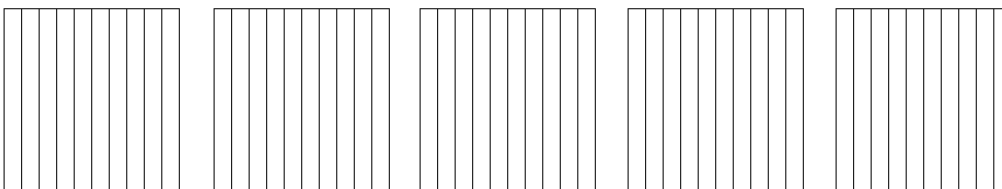

How much more is needed to get to 5? _____

Name _____

Date _____

1. Circle groups of tenths to make as many ones as possible.

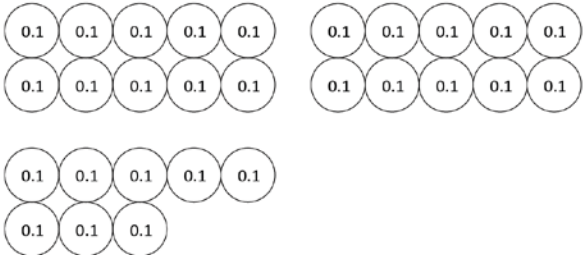
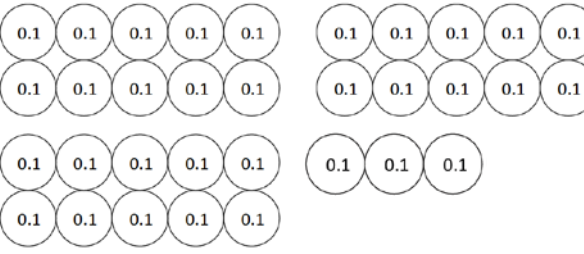
<p>a. How many tenths in all?</p>  <p>There are _____ tenths.</p>	<p>Write and draw the same number using ones and tenths.</p> <p>Decimal Form: _____</p> <p>How much more is needed to get to 3? _____</p>
<p>b. How many tenths in all?</p>  <p>There are _____ tenths.</p>	<p>Write and draw the same number using ones and tenths.</p> <p>Decimal Form: _____</p> <p>How much more is needed to get to 4? _____</p>

2. Draw disks to represent each number using tens, ones, and tenths. Then, show the expanded form of the number in fraction form and decimal form as shown. The first one has been completed for you.

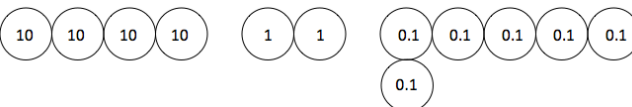
<p>a. 4 tens 2 ones 6 tenths</p>  <p>Fraction Expanded Form $(4 \times 10) + (2 \times 1) + (6 \times \frac{1}{10}) = 42 \frac{6}{10}$</p> <p>Decimal Expanded Form $(4 \times 10) + (2 \times 1) + (6 \times 0.1) = 42.6$</p>	<p>b. 1 ten 7 ones 5 tenths</p>
--	--

c. 2 tens 3 ones 2 tenths	d. 7 tens 4 ones 7 tenths
---------------------------	---------------------------

3. Complete the chart.

Point	Number Line	Decimal Form	Mixed Number (ones and fraction form)	Expanded Form (fraction or decimal form)	How much to get to the next one?
a.			$3\frac{9}{10}$		0.1
b.					
c.				$(7 \times 10) + (4 \times 1) + (7 \times \frac{1}{10})$	
d.			$22\frac{2}{10}$		
e.				$(8 \times 10) + (8 \times 0.1)$	

Name _____

Date _____

1. a. What is the length of the shaded part of the meter stick in centimeters?

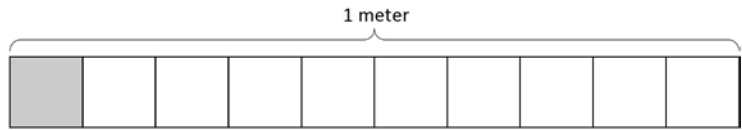

- b. What fraction of a meter is 1 centimeter?

- c. In fraction form, express the length of the shaded portion of the meter stick.

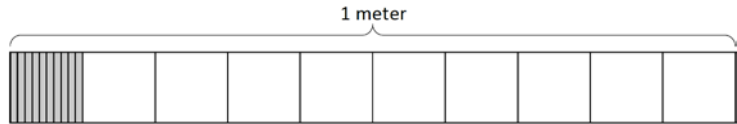

- d. In decimal form, express the length of the shaded portion of the meter stick.

- e. What fraction of a meter is 10 centimeters?

2. Fill in the blanks.

a. 1 tenth = ____ hundredths

b. $\frac{1}{10}$ m = $\frac{\quad}{100}$ m

c. $\frac{2}{10}$ m = $\frac{20}{\quad}$ m

3. Use the model to add the shaded parts as shown. Write a number bond with the total written in decimal form and the parts written as fractions. The first one has been done for you.

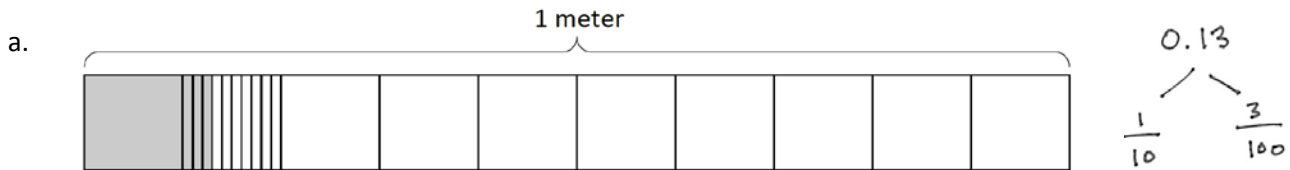

$$\frac{1}{10} \text{ m} + \frac{3}{100} \text{ m} = \frac{13}{100} \text{ m} = 0.13 \text{ m}$$

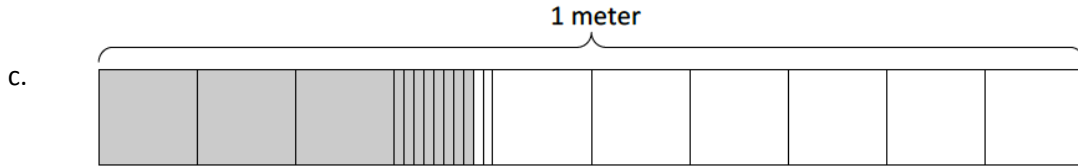
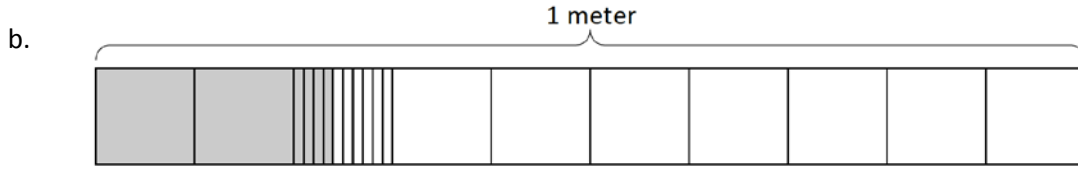

4. On each meter stick, shade in the amount shown. Then, write the equivalent decimal.

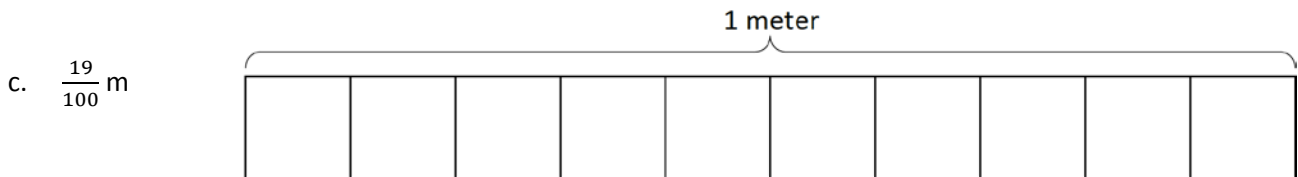
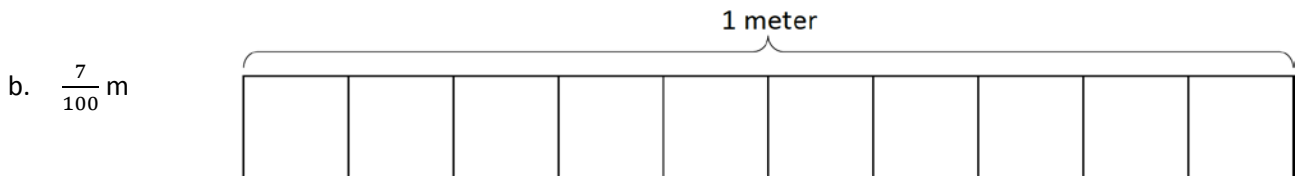
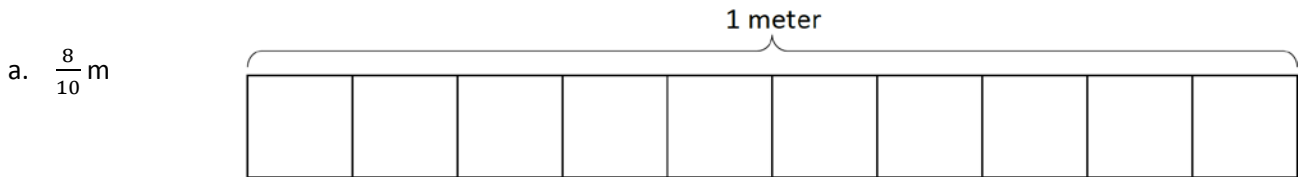

5. Draw a number bond, pulling out the tenths from the hundredths as in Problem 3. Write the total as the equivalent decimal.

a. $\frac{19}{100}$ m

b. $\frac{28}{100}$ m

c. $\frac{77}{100}$

d. $\frac{94}{100}$

Name _____

Date _____

1. Find the equivalent fraction using multiplication or division. Shade the area models to show the equivalency. Record it as a decimal.

a. $\frac{3 \times}{10 \times} = \frac{\quad}{100}$

b. $\frac{50 \div}{100 \div} = \frac{\quad}{10}$

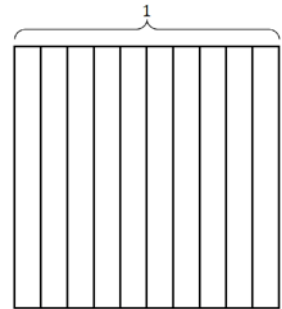
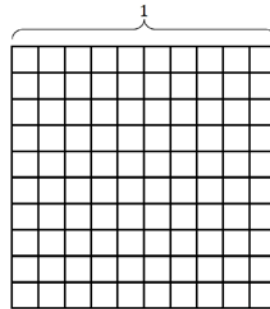
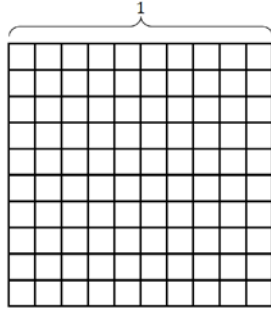
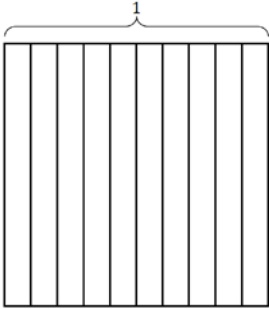

2. Complete the number sentences. Shade the equivalent amount on the area model, drawing horizontal lines to make hundredths.

a. 37 hundredths = _____ tenths + _____ hundredths

Fraction form: _____

Decimal form: _____

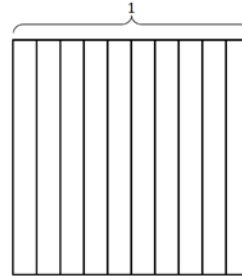

b. 75 hundredths = _____ tenths + _____ hundredths

Fraction form: _____

Decimal form: _____

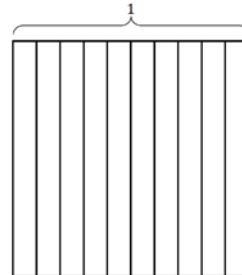

3. Circle hundredths to compose as many tenths as you can. Complete the number sentences. Represent each with a number bond as shown.

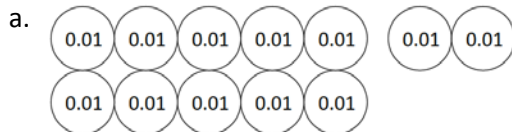

_____ hundredths = _____ tenth + _____ hundredths

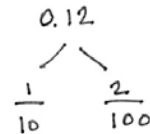

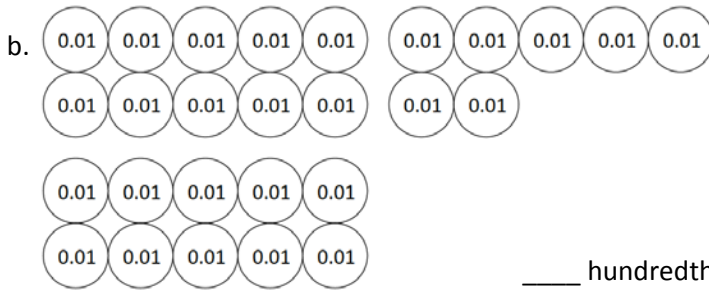

_____ hundredths = _____ tenths + _____ hundredths

4. Use both tenths and hundredths number disks to represent each number. Write the equivalent number in decimal, fraction, and unit form.

<p>a. $\frac{3}{100} = 0.$ _____ _____ hundredths</p>	<p>b. $\frac{15}{100} = 0.$ _____ _____ tenth _____ hundredths</p>
<p>c. _____ = 0.72 _____ hundredths</p>	<p>d. _____ = 0.80 _____ tenths</p>
<p>e. _____ = 0. _____ 7 tenths 2 hundredths</p>	<p>f. _____ = 0. _____ 80 hundredths</p>

Name _____

Date _____

1. Use a protractor to measure the angles, and then record the measurements in degrees.

a.

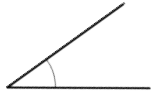

b.

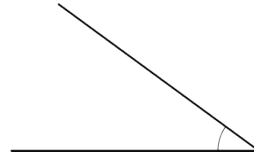

c.

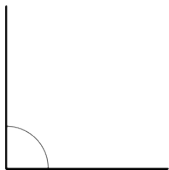

d.



e.

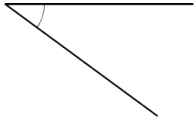

f.



g.

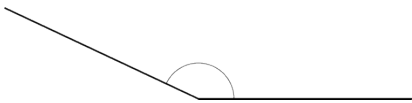

h.

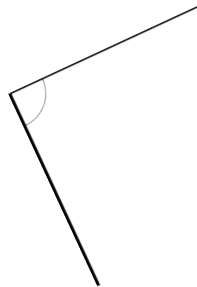

i.

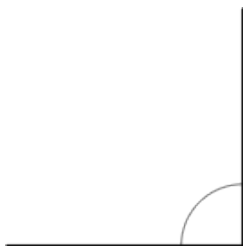

j.



2. a. Use three different-size protractors to measure the angle. Extend the lines as needed using a straightedge.

Protractor #1: _____ °

Protractor #2: _____ °

Protractor #3: _____ °

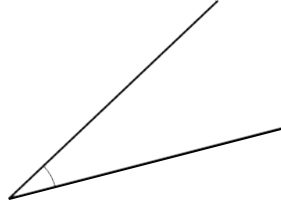

- b. What do you notice about the measurement of the above angle using each of the protractors?

3. Use a protractor to measure each angle. Extend the length of the segments as needed. When you extend the segments, does the angle measure stay the same? Explain how you know.

a.

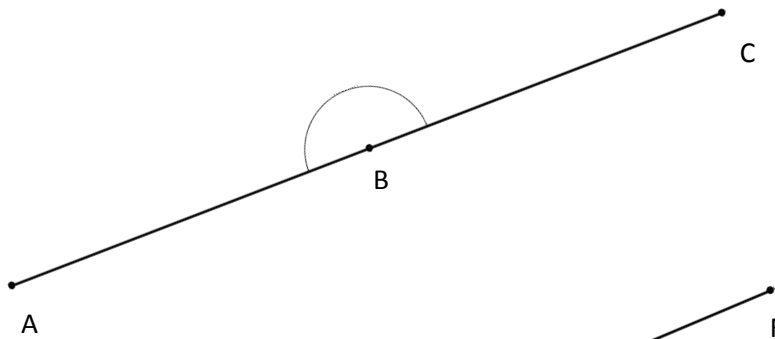

b.

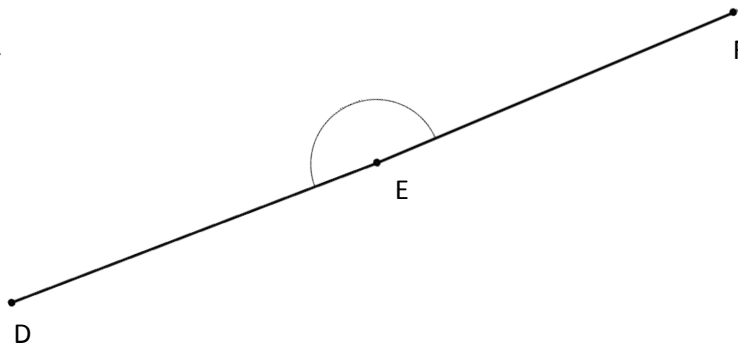

Name _____

Date _____

Construct angles that measure the given number of degrees. For Problems 1–4, use the ray shown as one of the rays of the angle with its endpoint as the vertex of the angle. Draw an arc to indicate the angle that was measured.

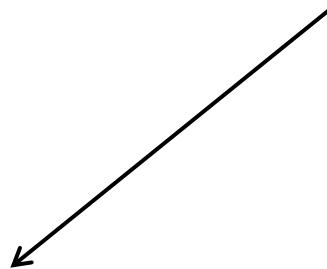
1. 30° 2. 65° 3. 115° 4. 135° 

5. 5° 6. 175° 7. 27° 8. 117° 9. 48° 10. 132°

Name _____

Date _____

1. Joe, Steve, and Bob stood in the middle of the yard and faced the house. Joe turned 90° to the right. Steve turned 180° to the right. Bob turned 270° to the right. Name the object that each boy is now facing.

Joe _____

Steve _____

Bob _____

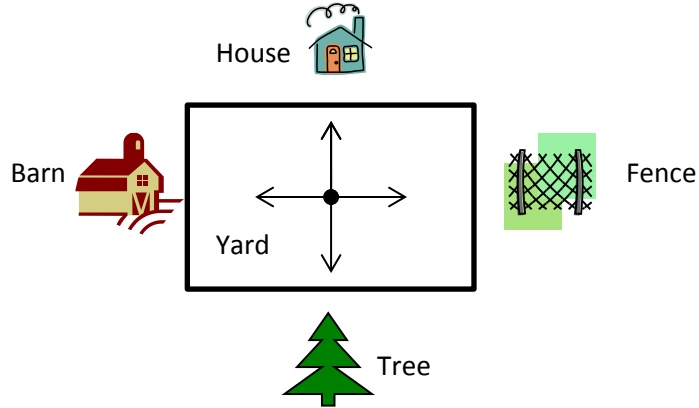

2. Monique looked at the clock at the beginning of class and at the end of class. How many degrees did the minute hand turn from the beginning of class until the end?

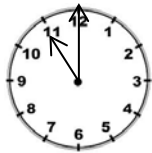

Beginning

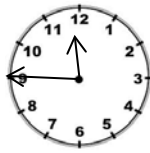

End

3. The skater jumped into the air and did a 360. What does that mean?

4. Mr. Martin drove away from his house without his wallet. He did a 180. Where is he heading now?



House



Store

5. John turned the knob of the shower 270° to the right. Draw a picture showing the position of the knob after he turned it.

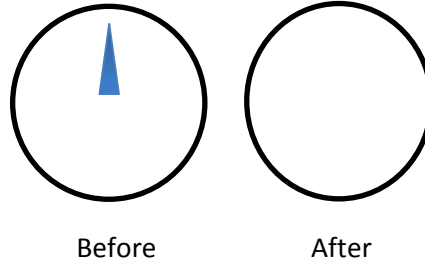

6. Barb used her scissors to cut out a coupon from the newspaper. How many quarter-turns does she need to turn the paper in order to stay on the lines?



7. How many quarter-turns does the picture need to be rotated in order for it to be upright?





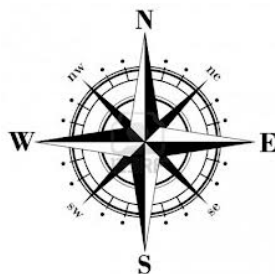

8. Meredith faced north. She turned 90° to the right, and then 180° more. In which direction is she now facing?



Name _____

Date _____

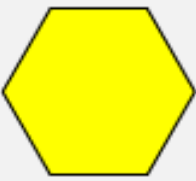
1. Complete the table.

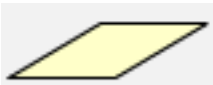
Pattern block	Total number that fit around 1 vertex	One interior angle measures...	Sum of the angles around a vertex
a. 		$360^\circ \div \underline{\quad} = \underline{\quad}$	$\underline{\quad} + \underline{\quad} + \underline{\quad} + \underline{\quad} = 360^\circ$
b. 			
c. 			$\underline{\quad} + \underline{\quad} + \underline{\quad} = 360^\circ$
d.  <i>(Acute angle)</i>			
e.  <i>(Obtuse angle)</i>			
f.  <i>(Acute angle)</i>			

2. Find the measurements of the angles indicated by the arcs.

Pattern blocks	Angle measure	Addition sentence
<p>a.</p>		
<p>b.</p>		
<p>c.</p>		

3. Use two or more pattern blocks to figure out the measurements of the angles indicated by the arcs.

Pattern blocks	Angle measure	Addition sentence
<p>a.</p>		
<p>b.</p>		
<p>c.</p>		

Name _____

Date _____

Write an equation and solve for the measure of $\angle x$. Verify the measurement using a protractor.

1. $\angle CBA$ is a right angle.

2. $\angle GFE$ is a right angle.

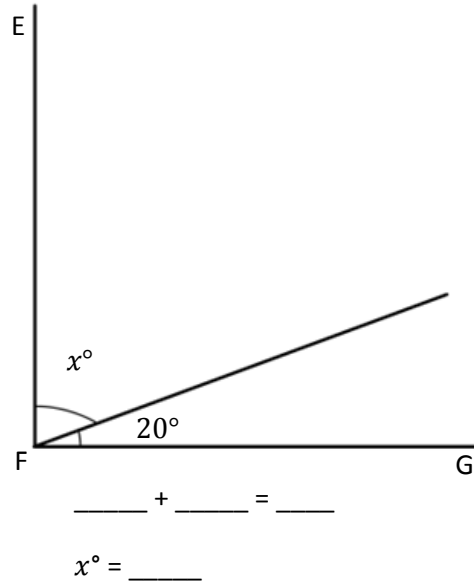
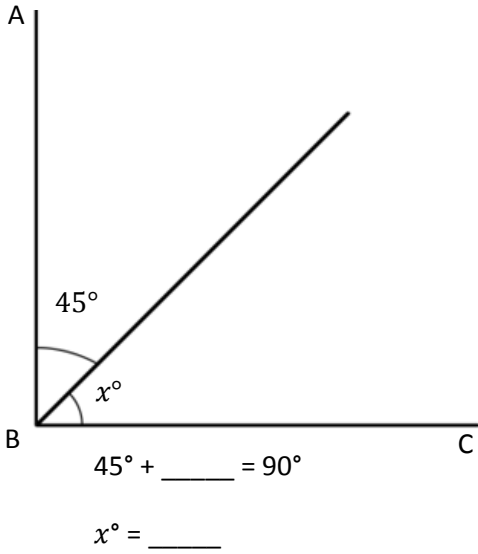

3. $\angle IJK$ is a straight angle.

4. $\angle MNO$ is a straight angle.

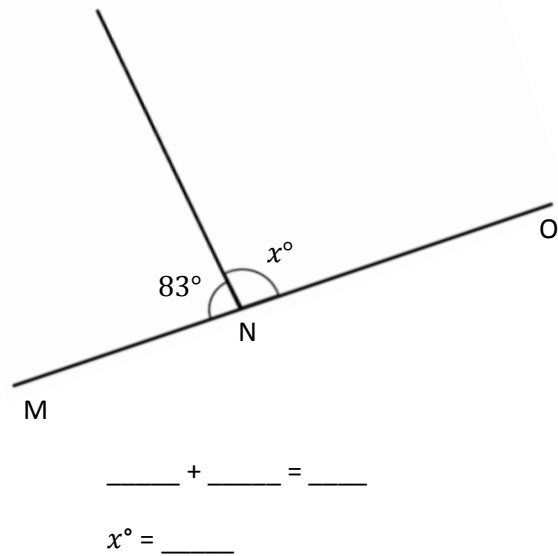
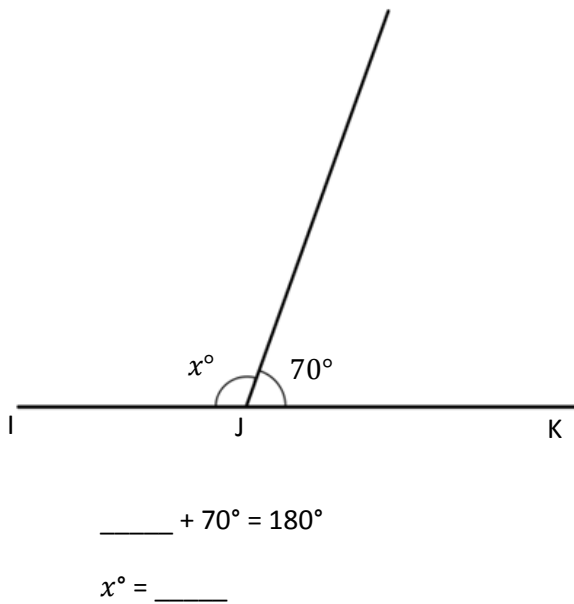

Solve for the unknown angle measurements. Write an equation to solve.

5. Solve for the measurement of $\angle TRU$.
 $\angle QRS$ is a straight angle.

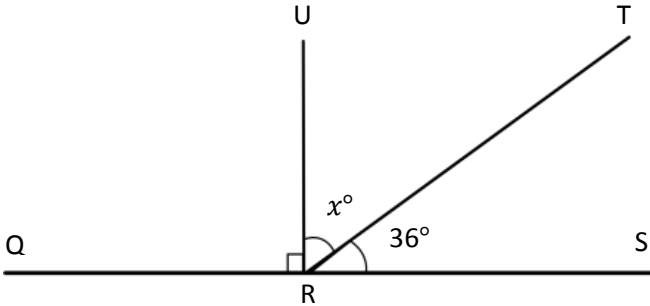

6. Solve for the measurement of $\angle ZYV$.
 $\angle XYZ$ is a straight angle.

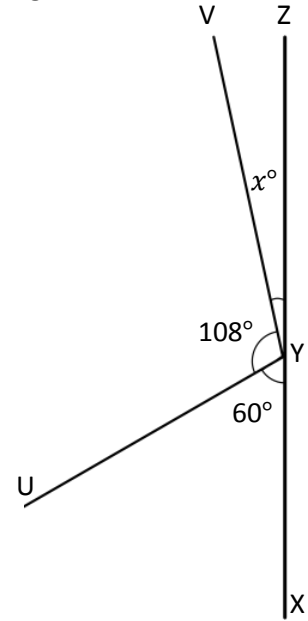

7. In the following figure, $ACDE$ is a rectangle. Without using a protractor, determine the measurement of $\angle DEB$. Write an equation that could be used to solve the problem.

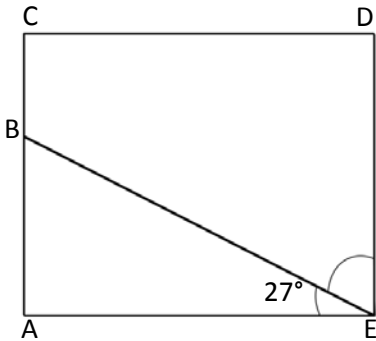

8. Complete the following directions in the space to the right.
- Draw 2 points: M and N . Using a straightedge, draw \overline{MN} .
 - Plot a point O somewhere between points M and N .
 - Plot a point P , which is not on \overline{MN} .
 - Draw \overline{OP} .
 - Find the measure of $\angle MOP$ and $\angle NOP$.
 - Write an equation to show that the angles add to the measure of a straight angle.

Name _____

Date _____

Write an equation, and solve for the unknown angle measurements numerically.

1.

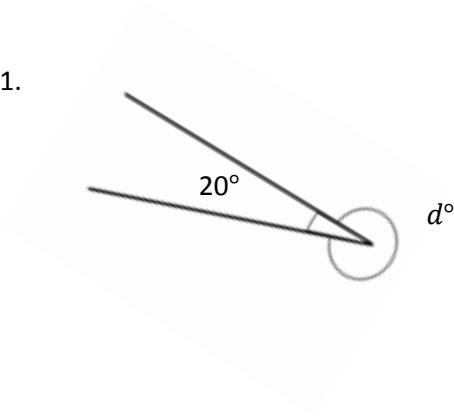

$$\underline{\hspace{1cm}}^\circ + 20^\circ = 360^\circ$$

$$d^\circ = \underline{\hspace{1cm}}^\circ$$

2.

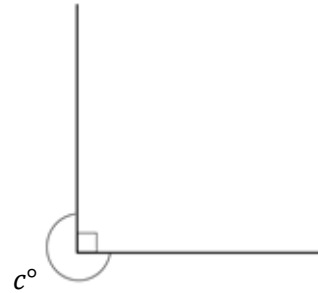

$$\underline{\hspace{1cm}}^\circ + \underline{\hspace{1cm}}^\circ = 360^\circ$$

$$c^\circ = \underline{\hspace{1cm}}^\circ$$

3.

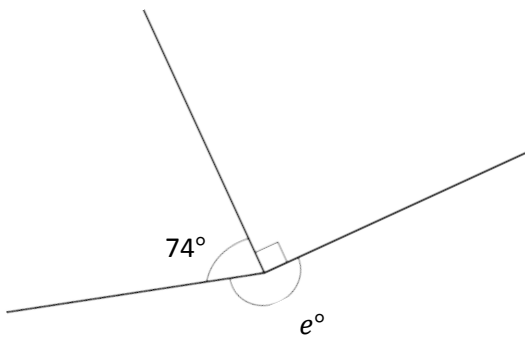

$$\underline{\hspace{1cm}}^\circ + \underline{\hspace{1cm}}^\circ + \underline{\hspace{1cm}}^\circ = \underline{\hspace{1cm}}^\circ$$

$$e^\circ = \underline{\hspace{1cm}}^\circ$$

4.

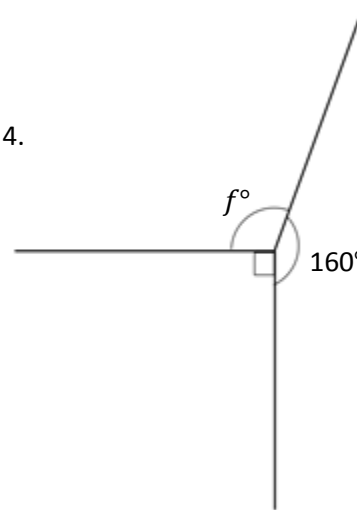

$$\underline{\hspace{1cm}}^\circ + \underline{\hspace{1cm}}^\circ + \underline{\hspace{1cm}}^\circ = \underline{\hspace{1cm}}^\circ$$

$$f^\circ = \underline{\hspace{1cm}}^\circ$$

Write an equation, and solve for the unknown angles numerically.

5. O is the intersection of \overline{AB} and \overline{CD} . $x^\circ = \underline{\hspace{2cm}}$ $y^\circ = \underline{\hspace{2cm}}$
 $\angle DOA$ is 160° and $\angle AOC$ is 20° .

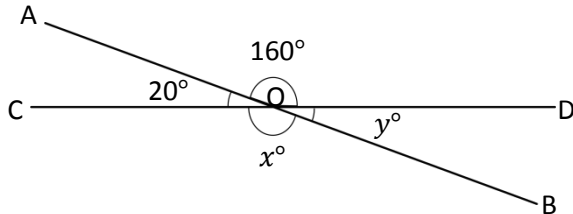

6. O is the intersection of \overline{RS} and \overline{TV} . $g^\circ = \underline{\hspace{2cm}}$ $h^\circ = \underline{\hspace{2cm}}$ $i^\circ = \underline{\hspace{2cm}}$
 $\angle TOS$ is 125° .

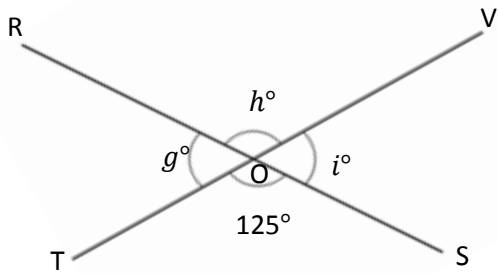

7. O is the intersection of \overline{WX} , \overline{YZ} , and \overline{UO} . $k^\circ = \underline{\hspace{2cm}}$ $m^\circ = \underline{\hspace{2cm}}$ $n^\circ = \underline{\hspace{2cm}}$
 $\angle XOZ$ is 36° .

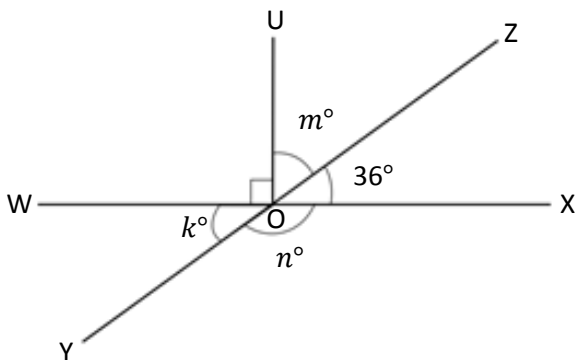

Name _____

Date _____

1. Circle the figures that have a correct line of symmetry drawn.

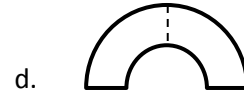
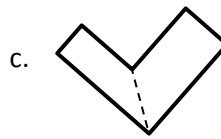
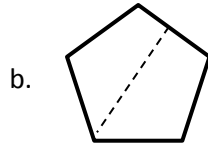
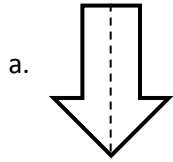

2. Find and draw all lines of symmetry for the following figures. Write the number of lines of symmetry that you found in the blank underneath the shape.

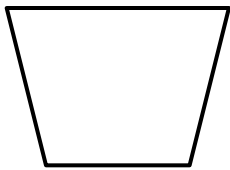

a. _____

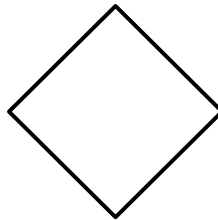

b. _____

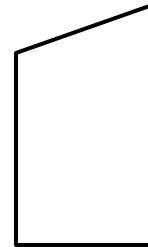

c. _____

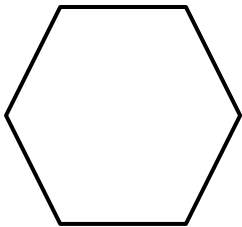

d. _____

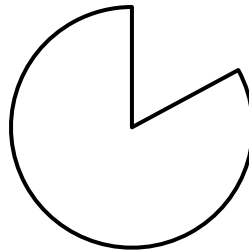

e. _____

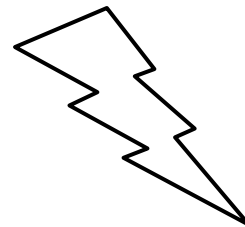

f. _____

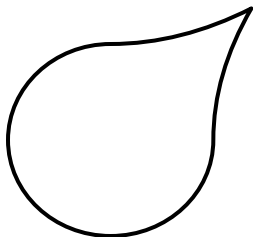

g. _____

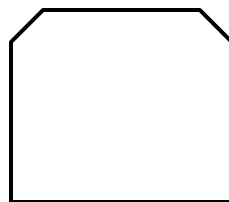

h. _____

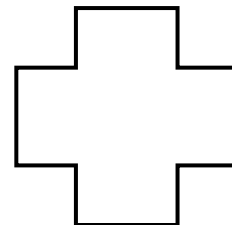

i. _____

3. Half of each figure below has been drawn. Use the line of symmetry, represented by the dashed line, to complete each figure.

a)

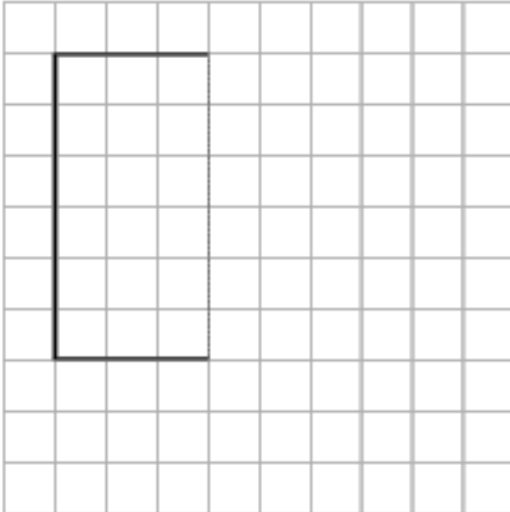

b)

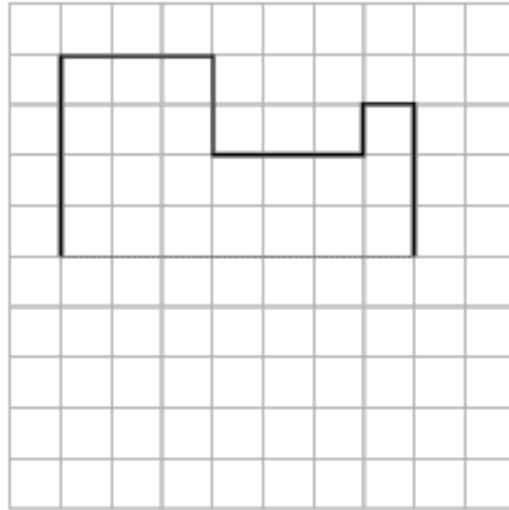

c)

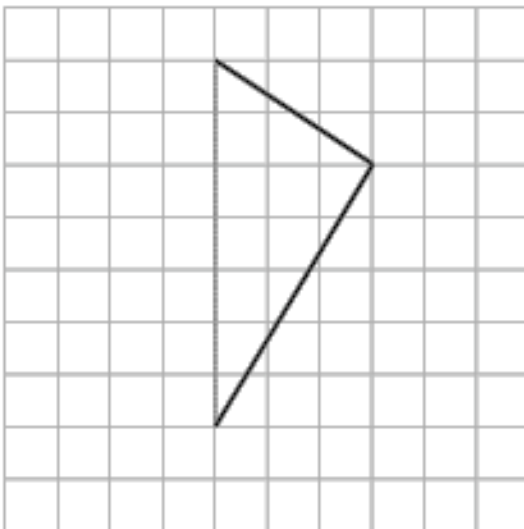

d)

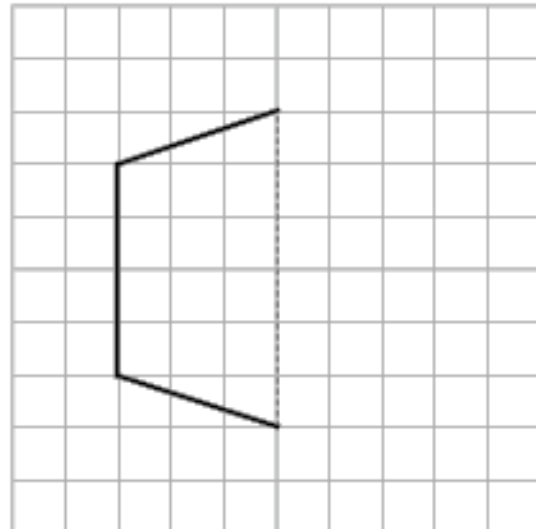

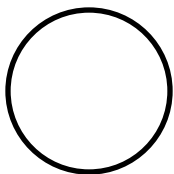

4. The figure below is a circle. How many lines of symmetry does the figure have? Explain.



Name _____

Date _____

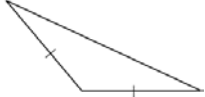
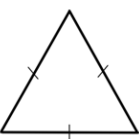
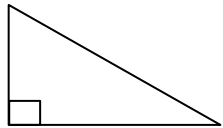
1. Classify each triangle by its side lengths and angle measurements. Circle the correct names.

	Classify Using Side Lengths	Classify Using Angle Measurements
a. 	Equilateral Isosceles Scalene	Acute Right Obtuse
b. 	Equilateral Isosceles Scalene	Acute Right Obtuse
c. 	Equilateral Isosceles Scalene	Acute Right Obtuse
d. 	Equilateral Isosceles Scalene	Acute Right Obtuse

2. $\triangle ABC$ has one line of symmetry as shown. What does this tell you about the measures of $\angle A$ and $\angle C$?

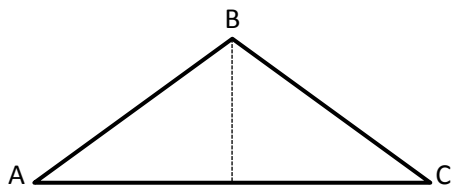

3. $\triangle DEF$ has three lines of symmetry as shown.

a. How can the lines of symmetry help you to figure out which angles are equal?

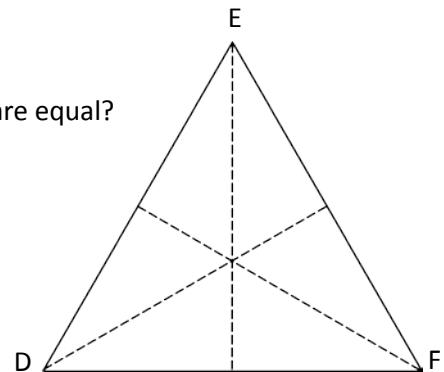

b. $\triangle DEF$ has a perimeter of 30 cm. Label the side lengths.

4. Use a ruler to connect points to form two other triangles. Use each point only once. None of the triangles may overlap. One or two points will be unused. Name and classify the three triangles below. The first one has been done for you.

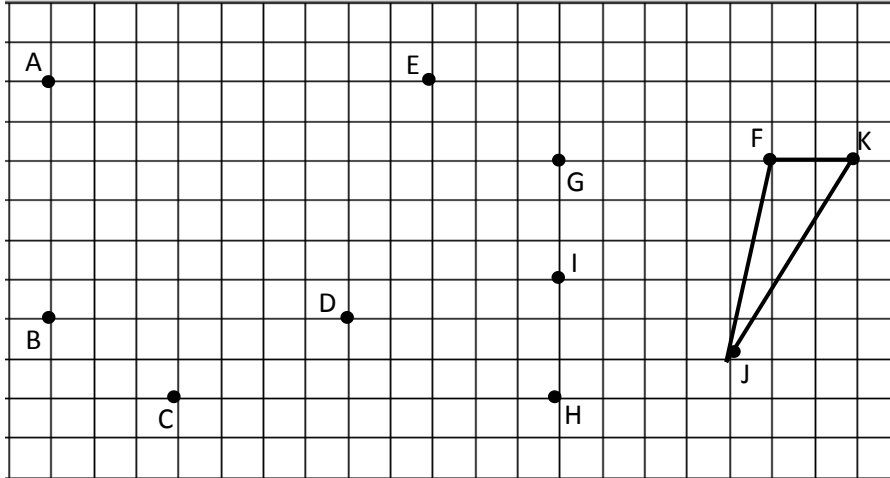

Name the Triangles Using Vertices	Classify by Side Length	Classify by Angle Measurement
$\triangle FJK$	Scalene	Obtuse

5. a. List three points from the grid above that, when connected by segments, do not result in a triangle.
- b. Why didn't the three points you listed result in a triangle when connected by segments?
6. Can a triangle have two right angles? Explain.

Name _____

Date _____

1. Draw triangles that fit the following classifications. Use a ruler and protractor. Label the side lengths and angles.

a. Right and isosceles

b. Obtuse and scalene

c. Acute and scalene

d. Acute and isosceles

2. Draw all possible lines of symmetry in the triangles above. Explain why some of the triangles do not have lines of symmetry.

Are the following statements true or false? Explain using pictures or words.

3. If $\triangle ABC$ is an equilateral triangle, \overline{BC} must be 2 cm. True or False?

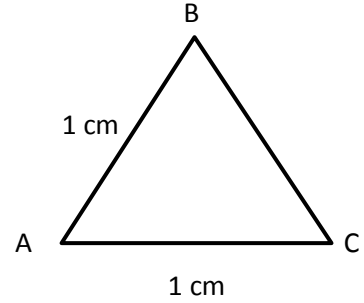

4. A triangle cannot have one obtuse angle and one right angle. True or False?

5. $\triangle EFG$ can be described as a right triangle and an isosceles triangle. True or False?

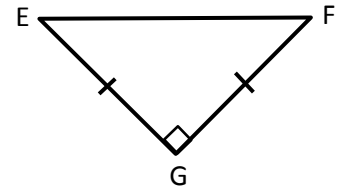

6. An equilateral triangle is isosceles. True or False?

Extension: In $\triangle HIJ$, $a = b$. True or False?

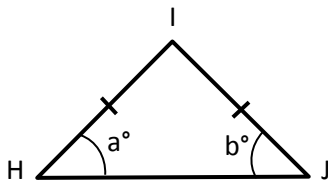

Name _____

Date _____

Construct the figures with the given attributes. Name the shape you created. Be as specific as possible. Use extra blank paper as needed.

1. Construct quadrilaterals with at least one set of parallel sides.

2. Construct a quadrilateral with two sets of parallel sides.

3. Construct a parallelogram with four right angles.

4. Construct a rectangle with all sides the same length.

5. Use the word bank to name each shape, being as specific as possible.

Parallelogram	Trapezoid	Rectangle	Square
---------------	-----------	-----------	--------

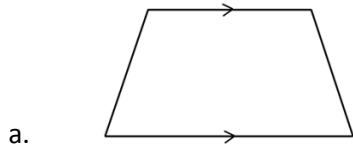

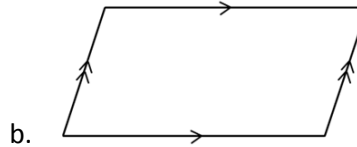

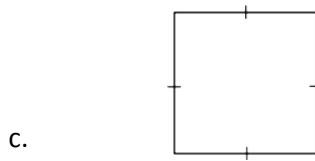

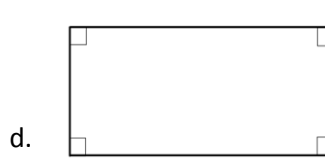

6. Explain the attribute that makes a square a special rectangle.



7. Explain the attribute that makes a rectangle a special parallelogram.

8. Explain the attribute that makes a parallelogram a special trapezoid.

Name _____

Date _____

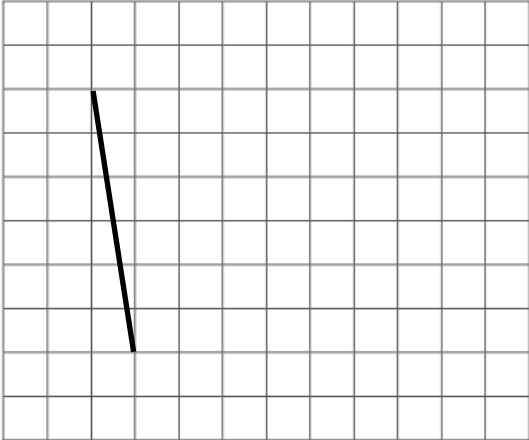
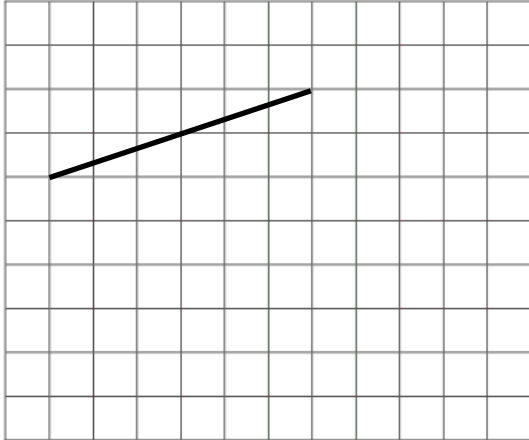
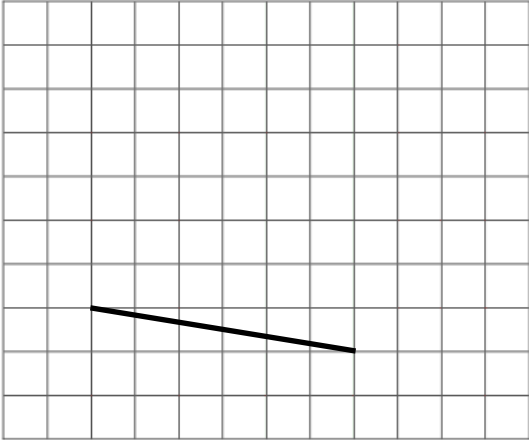
1. On the grid paper, draw at least one quadrilateral to fit the description. Use the given segment as one segment of the quadrilateral. Name the figure you drew using one of the terms below.

Parallelogram Square	Trapezoid	Rectangle	Rhombus
<p>a. A quadrilateral that has at least one pair of parallel sides.</p> 	<p>b. A quadrilateral that has four right angles.</p> 		
<p>c. A quadrilateral that has two pairs of parallel sides.</p> 	<p>d. A quadrilateral that has at least one pair of perpendicular sides and at least one pair of parallel sides.</p> 		

2. On the grid paper, draw at least one quadrilateral to fit the description. Use the given segment as one segment of the quadrilateral. Name the figure you drew using one of the terms below.

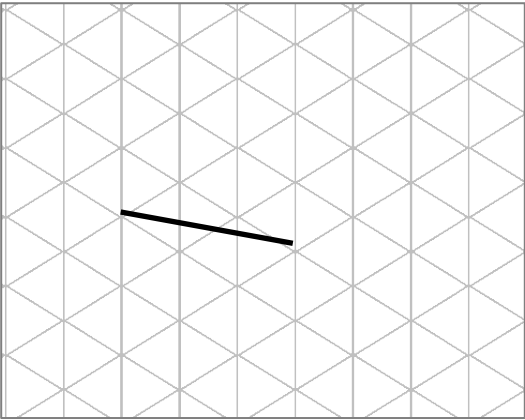
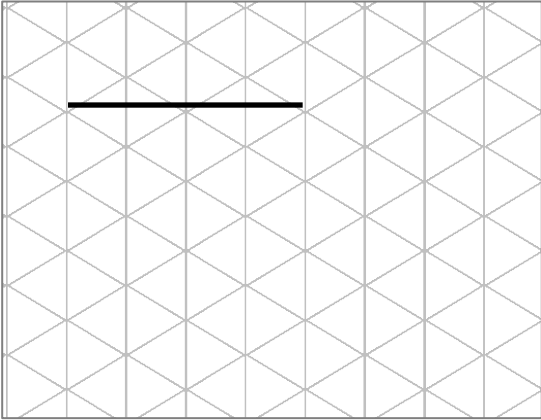
Parallelogram Square	Trapezoid	Rectangle Rhombus
<p>a. A quadrilateral that has two sets of parallel sides.</p> 	<p>b. A quadrilateral that has four right angles.</p> 	

3. Explain the attributes that make a rhombus different from a rectangle.

4. Explain the attribute that makes a square different from a rhombus.

Name _____ Date _____

1. Shade the first 4 units of the tape diagram. Count by tenths to label the number line using a fraction and a decimal for each point. Circle the decimal that represents the shaded part.

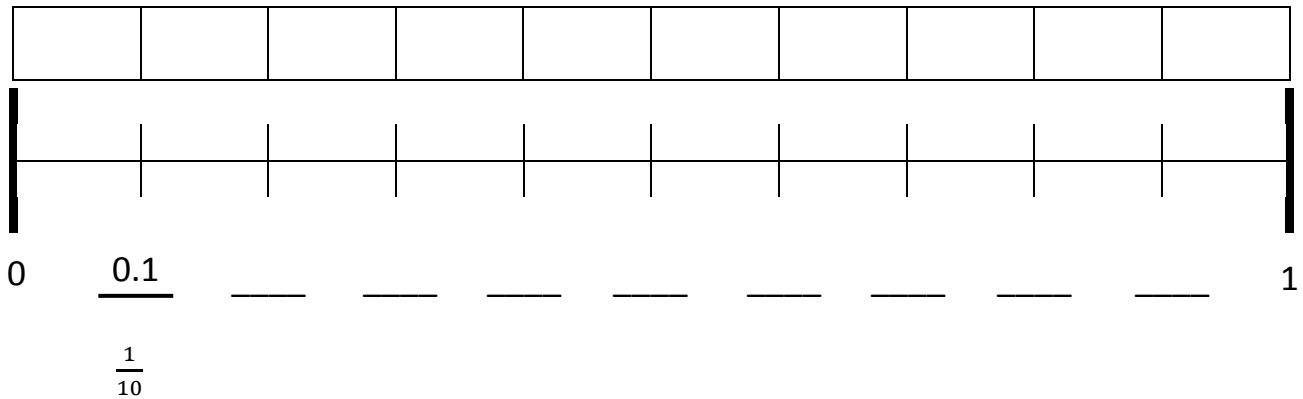

2. Write the total amount of water in fraction form and decimal form. Shade the last bottle to show the correct amount.

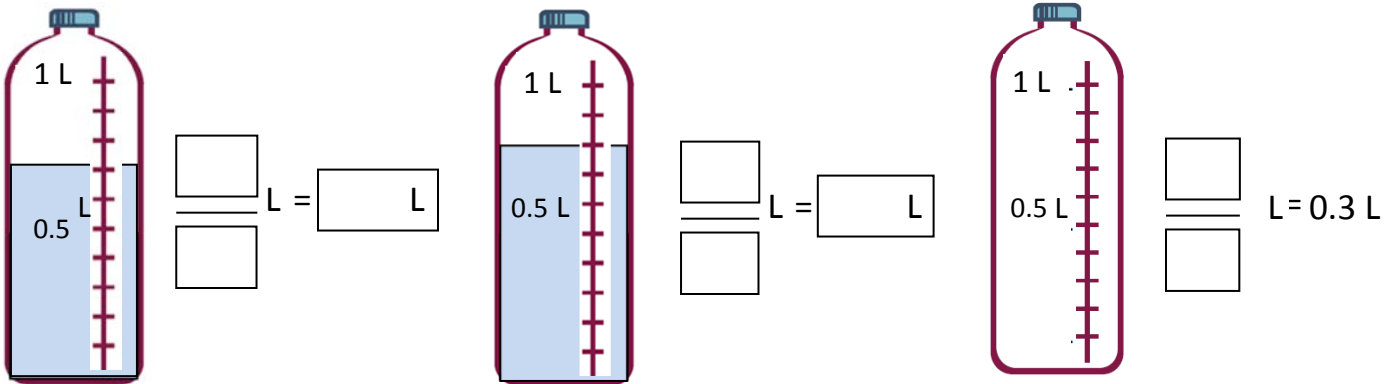

3. Write the total weight of the food on each scale in fraction form or decimal form.

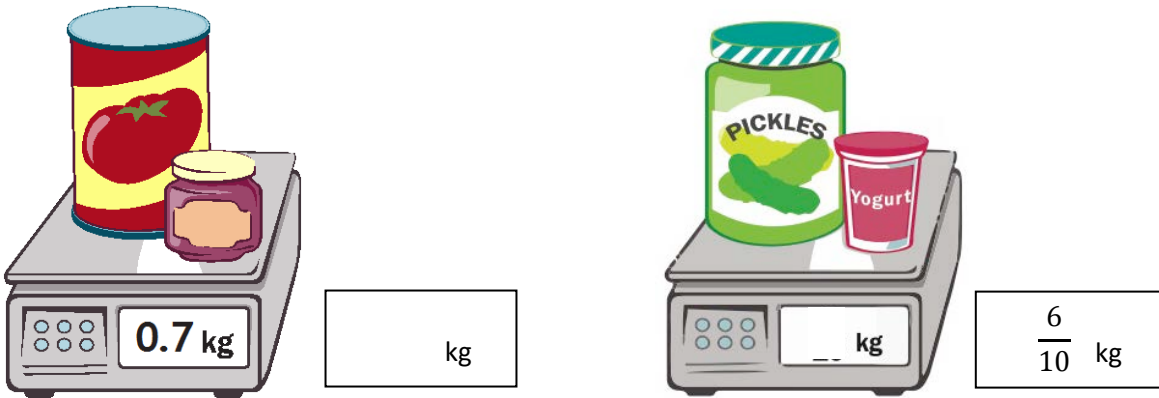

4. Write the length of the bug in centimeters. (Drawing is not to scale.)



Fraction form: _____ cm

Decimal form: _____ cm

If the bug walks 0.5 cm farther, where will its nose be? _____ cm

5. Fill in the blank to make the sentence true in both fraction and decimal form.

a. $\frac{4}{10}$ cm + _____ cm = 1 cm

0.4 cm + _____ cm = 1.0 cm

b. $\frac{3}{10}$ cm + _____ cm = 1 cm

0.3 cm + _____ cm = 1.0 cm

c. $\frac{8}{10}$ cm + _____ cm = 1 cm

0.8 cm + _____ cm = 1.0 cm

6. Match each amount expressed in unit form to its equivalent fraction and decimal.

2 tenths	$\frac{4}{10}$	0.4
4 tenths	$\frac{7}{10}$	0.6
6 tenths	$\frac{5}{10}$	0.2
7 tenths	$\frac{2}{10}$	0.5
5 tenths	$\frac{6}{10}$	0.7

Hand-drawn lines connect '2 tenths' to $\frac{2}{10}$ and $\frac{2}{10}$ to 0.2.

Name _____

Date _____

1. For each length given below, draw a line segment to match. Express each measurement as an equivalent mixed number.

a. 2.6 cm

b. 3.5 cm

c. 1.7 cm

d. 4.3 cm

e. 2.2 cm

2. Write the following in decimal form. Then, model and rename the number as shown below.

a. 2 ones and 4 tenths = _____

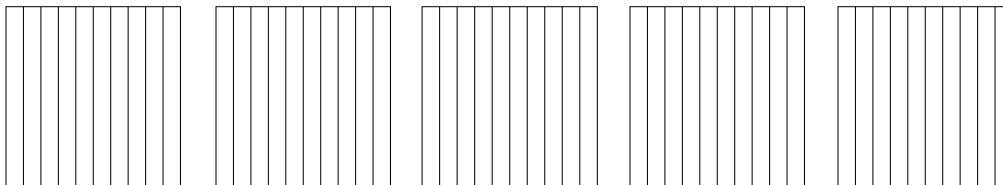

$$2\frac{4}{10} = 2 + \frac{4}{10} = 2 + 0.4 = 2.4$$

b. 3 ones and 8 tenths = _____

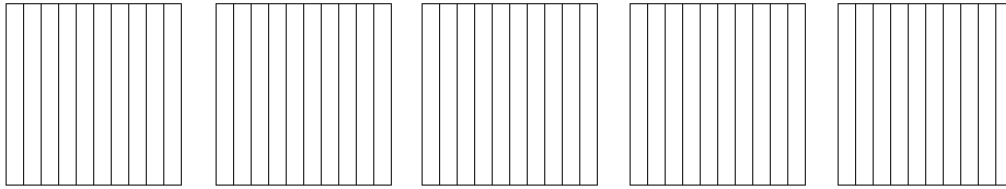

c. $4\frac{1}{10}$ = _____

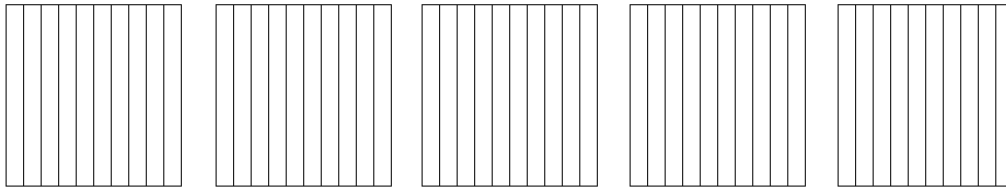

d. $1\frac{4}{10}$ = _____

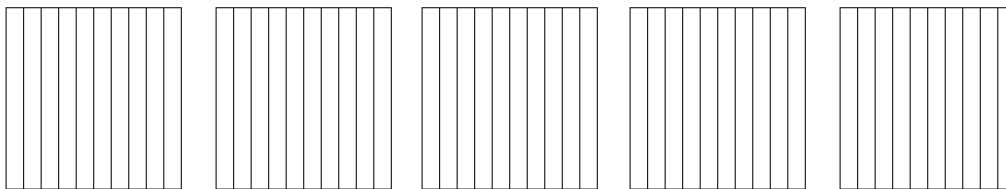

How much more is needed to get to 5? _____

e. $\frac{33}{10}$ = _____

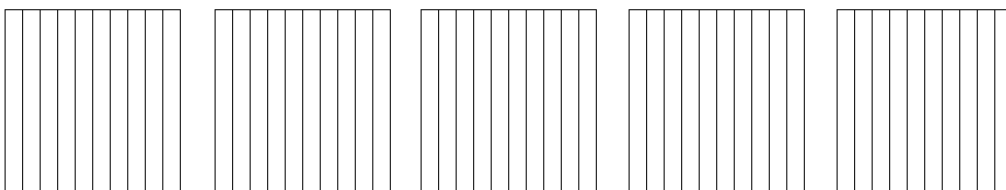

How much more is needed to get to 5? _____

Name _____

Date _____

1. Circle groups of tenths to make as many ones as possible.

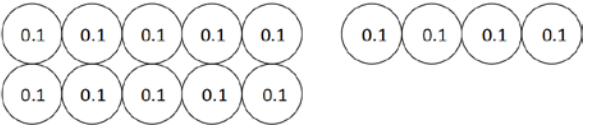
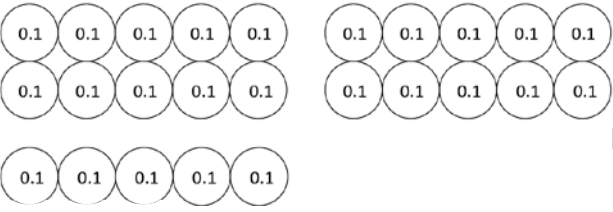

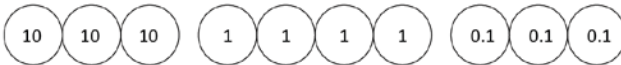

<p>a. How many tenths in all?</p>  <p>There are _____ tenths.</p>	<p>Write and draw the same number using ones and tenths.</p> <p>Decimal Form: _____</p> <p>How much more is needed to get to 2? _____</p>
<p>b. How many tenths in all?</p>  <p>There are _____ tenths.</p>	<p>Write and draw the same number using ones and tenths.</p> <p>Decimal Form: _____</p> <p>How much more is needed to get to 3? _____</p>

2. Draw disks to represent each number using tens, ones, and tenths. Then, show the expanded form of the number in fraction form and decimal form as shown. The first one has been completed for you.

<p>a. 3 tens 4 ones 3 tenths</p>  <p>Fraction Expanded Form $(3 \times 10) + (4 \times 1) + (3 \times \frac{1}{10}) = 34 \frac{3}{10}$</p> <p>Decimal Expanded Form $(3 \times 10) + (4 \times 1) + (3 \times 0.1) = 34.3$</p>	<p>b. 5 tens 3 ones 7 tenths</p>
---	----------------------------------

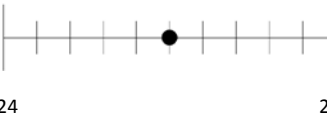
c. 3 tens 2 ones 3 tenths	d. 8 tens 4 ones 8 tenths
---------------------------	---------------------------

3. Complete the chart.

Point	Number Line	Decimal Form	Mixed Number (ones and fraction form)	Expanded Form (fraction or decimal form)	How much to get to the next one?
a.			$4\frac{6}{10}$		
b.					0.5
c.				$(6 \times 10) + (3 \times 1) + (6 \times \frac{1}{10})$	
d.			$71\frac{3}{10}$		
e.				$(9 \times 10) + (9 \times 0.1)$	

Name _____

Date _____

1. a. What is the length of the shaded part of the meter stick in centimeters?

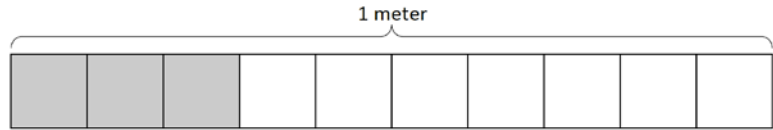

- b. What fraction of a meter is 3 centimeters?

- c. In fraction form, express the length of the shaded portion of the meter stick.

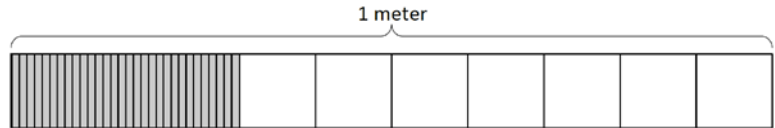

- d. In decimal form, express the length of the shaded portion of the meter stick.

- e. What fraction of a meter is 30 centimeters?

2. Fill in the blanks.

a. 5 tenths = ____ hundredths

b. $\frac{5}{10}$ m = $\frac{\quad}{100}$ m

c. $\frac{4}{10}$ m = $\frac{40}{\quad}$ m

3. Use the model to add the shaded parts as shown. Write a number bond with the total written in decimal form and the parts written as fractions. The first one has been done for you.

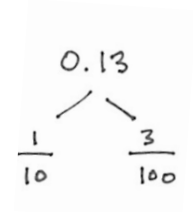
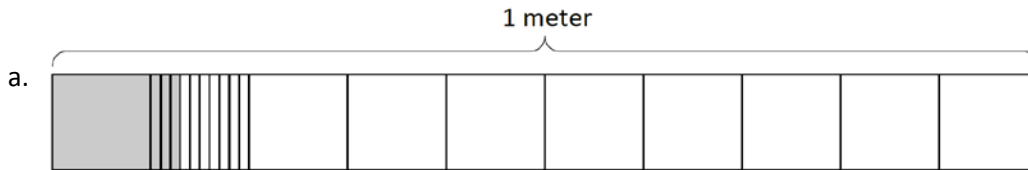

$$\frac{1}{10} \text{ m} + \frac{3}{100} \text{ m} = \frac{13}{100} \text{ m} = 0.13 \text{ m}$$

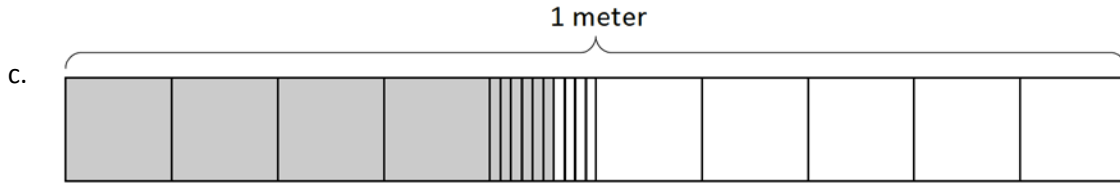
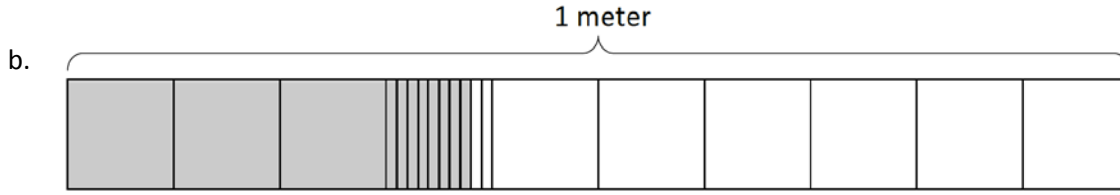

4. On each meter stick, shade in the amount shown. Then, write the equivalent decimal.

a. $\frac{9}{10}$ m

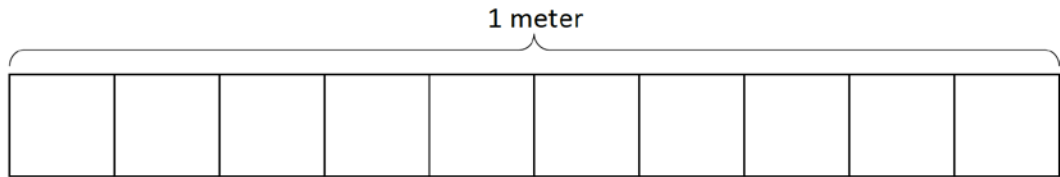

b. $\frac{15}{100}$ m

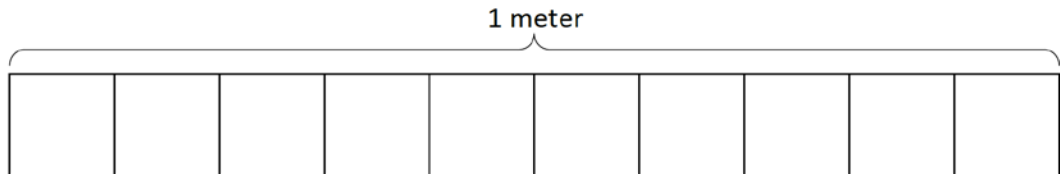

c. $\frac{41}{100}$ m

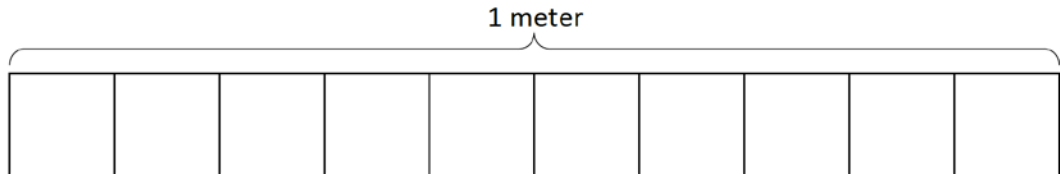

5. Draw a number bond, pulling out the tenths from the hundredths, as in Problem 3 of the Homework. Write the total as the equivalent decimal.

a. $\frac{23}{100}$ m

b. $\frac{38}{100}$ m

c. $\frac{82}{100}$

d. $\frac{76}{100}$

Name _____

Date _____

1. Find the equivalent fraction using multiplication or division. Shade the area models to show the equivalency. Record it as a decimal.

a. $\frac{4 \times \underline{\quad}}{10 \times \underline{\quad}} = \frac{\quad}{100}$

b. $\frac{60 \div \underline{\quad}}{100 \div \underline{\quad}} = \frac{\quad}{10}$

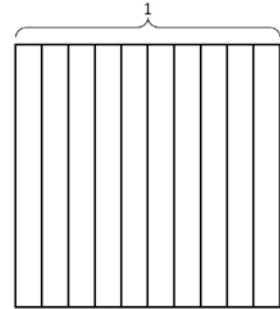
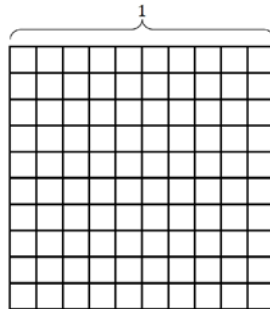
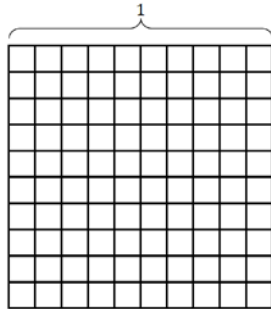
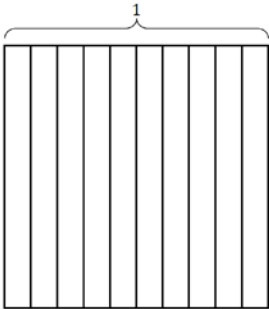

2. Complete the number sentences. Shade the equivalent amount on the area model, drawing horizontal lines to make hundredths.

a. 36 hundredths = _____ tenths + _____ hundredths

Decimal form: _____

Fraction form: _____

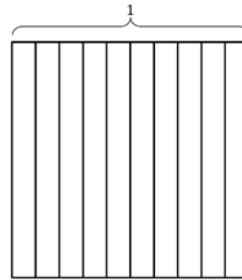

b. 82 hundredths = _____ tenths + _____ hundredths

Decimal form: _____

Fraction form: _____

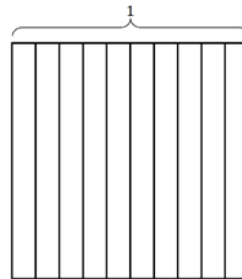

3. Circle hundredths to compose as many tenths as you can. Complete the number sentences. Represent each with a number bond as shown.

a.

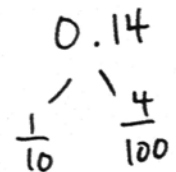

_____ hundredths = _____ tenth + _____ hundredths

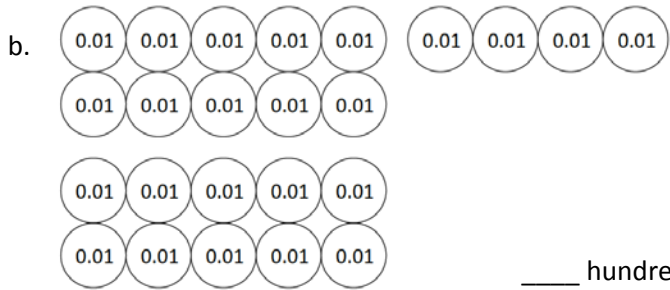

___ hundredths = ___ tenths + ___ hundredths

4. Use both tenths and hundredths number disks to represent each number. Write the equivalent number in decimal, fraction, and unit form.

<p>a. $\frac{4}{100} = 0.$ _____ _____ hundredths</p>	<p>b. $\frac{13}{100} = 0.$ _____ _____ tenth _____ hundredths</p>
<p>c. _____ = 0.41 _____ hundredths</p>	<p>d. _____ = 0.90 _____ tenths</p>
<p>e. _____ = 0. _____ 6 tenths 3 hundredths</p>	<p>f. _____ = 0. _____ 90 hundredths</p>

Name _____

Date _____

1. Use a protractor to measure the angles, and then record the measurements in degrees.

a.

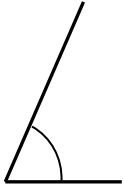

b.

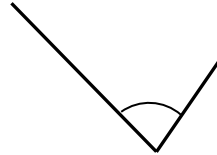

c.

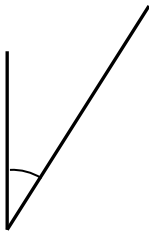

d.

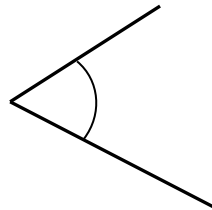

e.



f.

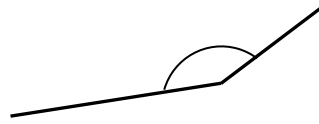

g.

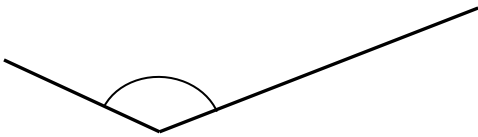

h.

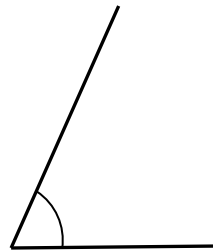

i.

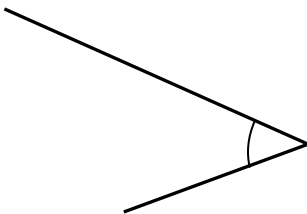

j.

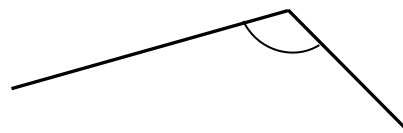

2. Using the green and red circle cutouts from today’s lesson, explain to someone at home how the cutouts can be used to show that the angle measures are the same even though the circles are different sizes. Write words to explain what you told him or her.

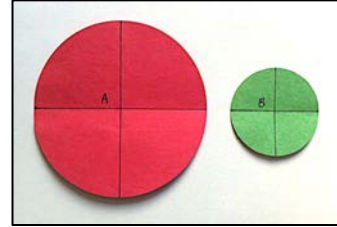

3. Use a protractor to measure each angle. Extend the length of the segments as needed. When you extend the segments, does the angle measure stay the same? Explain how you know.

a.

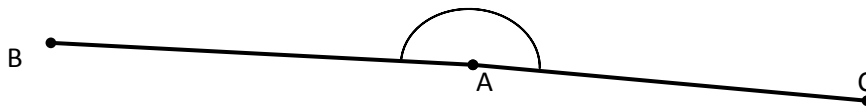

b.

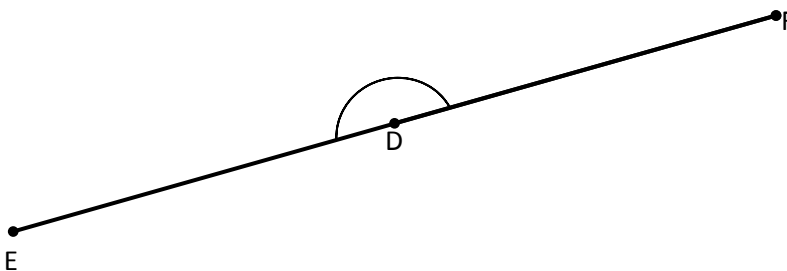

Name _____

Date _____

Construct angles that measure the given number of degrees. For Problems 1–4, use the ray shown as one of the rays of the angle with its endpoint as the vertex of the angle. Draw an arc to indicate the angle that was measured.

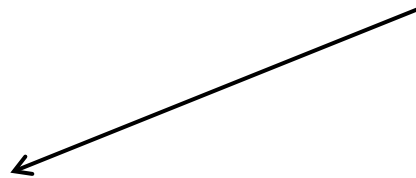
1. 25° 2. 85° 3. 140° 4. 83° 

5. 108° 6. 72° 7. 25° 8. 155° 9. 45° 10. 135°

Name _____

Date _____

1. Jill, Shyan, and Barb stood in the middle of the yard and faced the barn. Jill turned 90° to the right. Shyan turned 180° to the left. Barb turned 270° to the left. Name the object that each girl is now facing.

Jill _____

Shyan _____

Barb _____

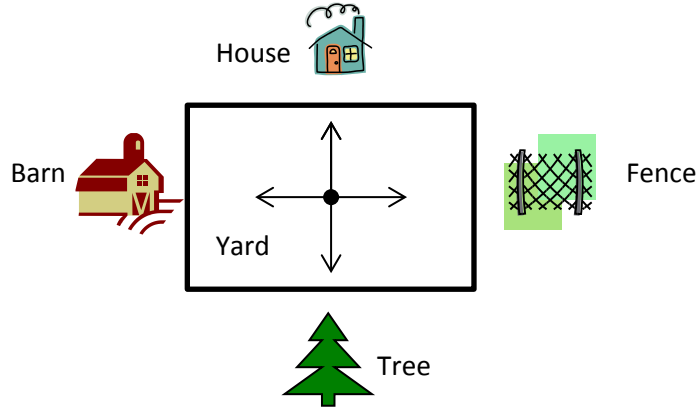

2. Allison looked at the clock at the beginning of class and at the end of class. How many degrees did the minute hand turn from the beginning of class until the end?

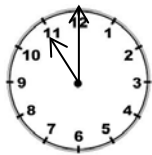

Beginning

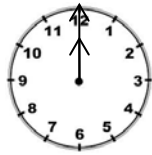

End

3. The snowboarder went off a jump and did a 180. In which direction was the snowboarder facing when he landed? How do you know?

4. As she drove down the icy road, Mrs. Campbell slammed on her brakes. Her car did a 360. Explain what happened to Mrs. Campbell's car.

5. Jonah turned the knob of the stove two quarter-turns. Draw a picture showing the position of the knob after he turned it.

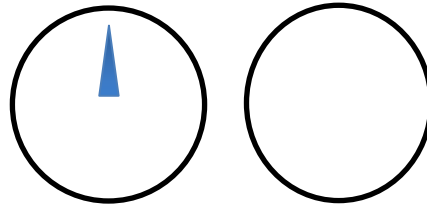

Before

After

6. Betsy used her scissors to cut out a coupon from the newspaper. How many total quarter-turns will she need to rotate the paper in order to cut out the entire coupon?



7. How many quarter-turns does the picture need to be rotated in order for it to be upright?



8. David faced north. He turned 180° to the right, and then 270° to the left. In which direction is he now facing?

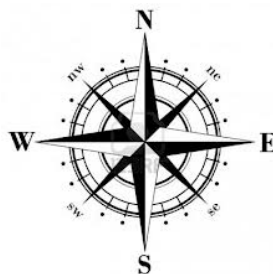

Name _____

Date _____

Sketch two different ways to compose the given angles using two or more pattern blocks.

Write an addition sentence to show how you composed the given angle.

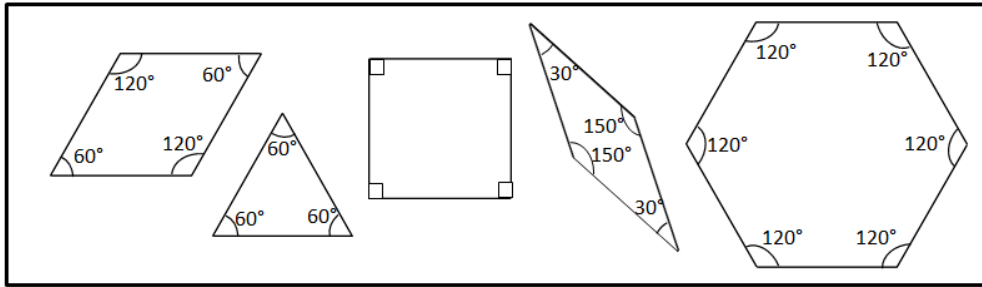

1. Points A , B , and C form a straight line.

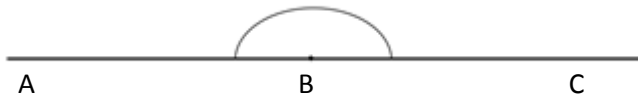

$180^\circ =$ _____

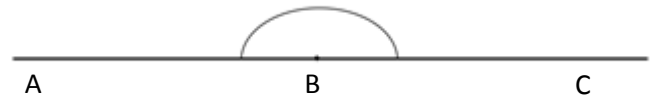

$180^\circ =$ _____

2. $\angle DEF = 90^\circ$

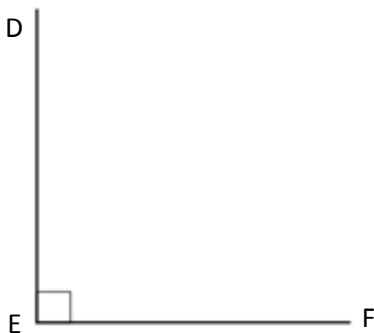

$90^\circ =$ _____

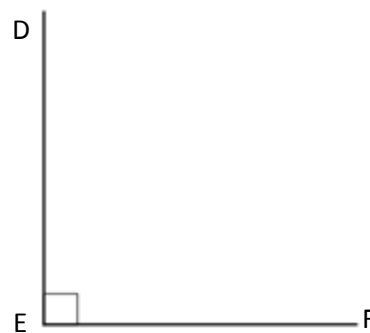

$90^\circ =$ _____

3. $\angle GHI = 120^\circ$

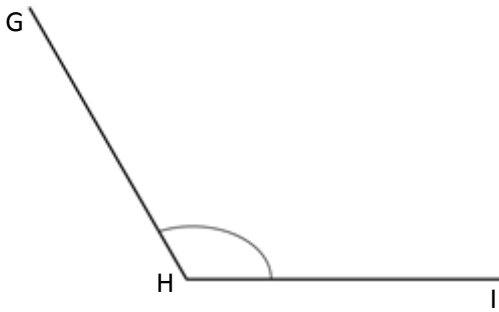

$120^\circ =$ _____

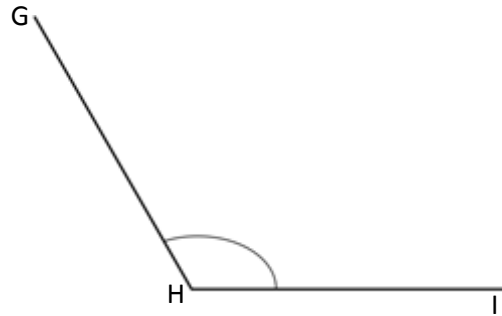

$120^\circ =$ _____

4. $x^\circ = 270^\circ$

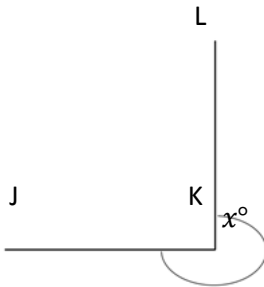

$270^\circ =$ _____

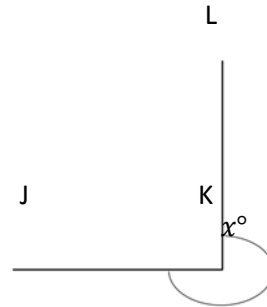

$270^\circ =$ _____

5. Micah built the following shape with his pattern blocks. Write an addition sentence for each angle indicated by an arc and solve. The first one is done for you.

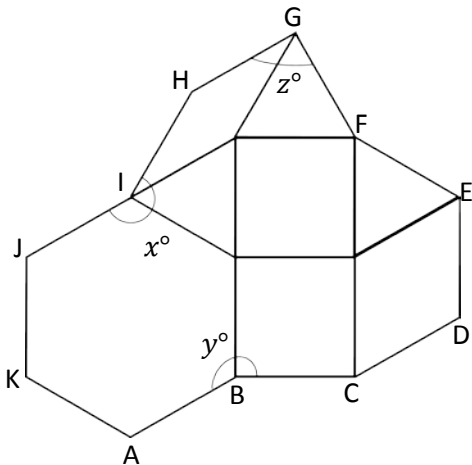

a. $y^\circ = 120^\circ + 90^\circ$

$y^\circ = 210^\circ$

b. $z^\circ =$ _____

$z^\circ =$ _____

c. $x^\circ =$ _____

$x^\circ =$ _____

Name _____

Date _____

Write an equation and solve for the measurement of $\angle x$. Verify the measurement using a protractor.

1. $\angle DCB$ is a right angle.

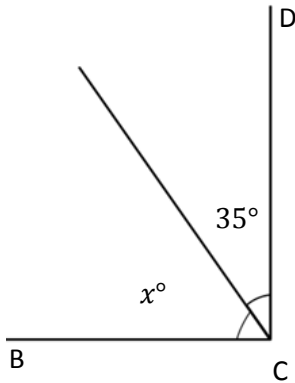

$$\underline{\hspace{2cm}} + 35^\circ = 90^\circ$$

$$x^\circ = \underline{\hspace{2cm}}$$

2. $\angle HGF$ is a right angle.

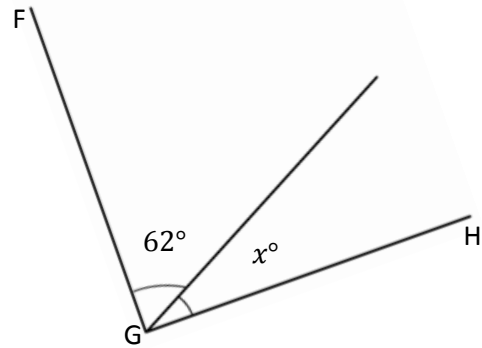

$$\underline{\hspace{2cm}} + \underline{\hspace{2cm}} = \underline{\hspace{2cm}}$$

$$x^\circ = \underline{\hspace{2cm}}$$

3. $\angle JKL$ is a straight angle.

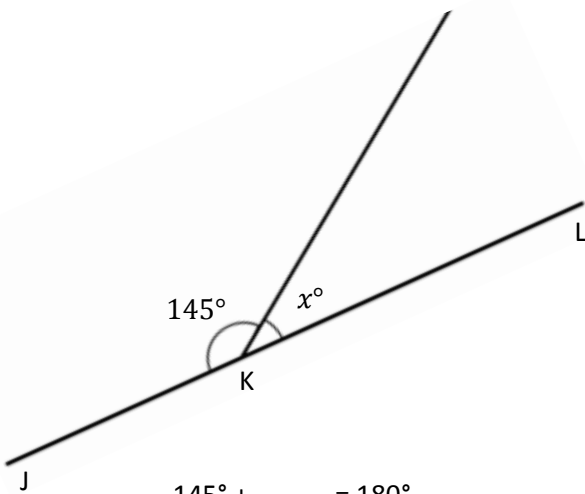

$$145^\circ + \underline{\hspace{2cm}} = 180^\circ$$

$$x^\circ = \underline{\hspace{2cm}}$$

4. $\angle PQR$ is a straight angle.

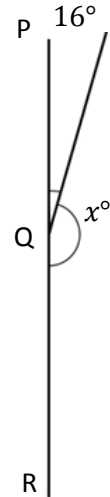

$$\underline{\hspace{2cm}} + \underline{\hspace{2cm}} = \underline{\hspace{2cm}}$$

$$x^\circ = \underline{\hspace{2cm}}$$

Write an equation and solve for the unknown angle measurements.

5. Solve for the measurement of $\angle USW$.
 $\angle RST$ is a straight angle.

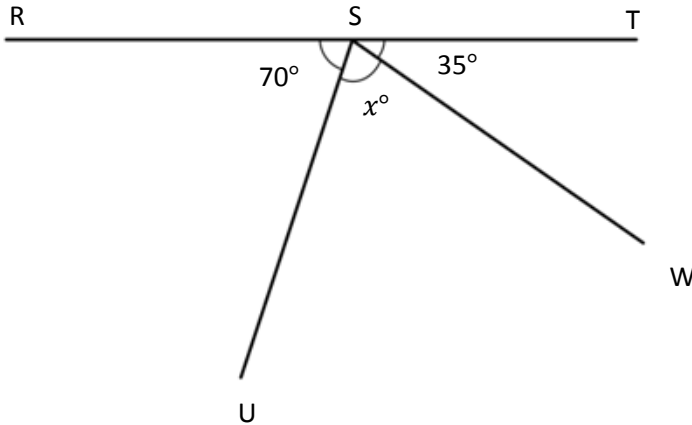

6. Solve for the measurement of $\angle OML$.
 $\angle LMN$ is a straight angle.

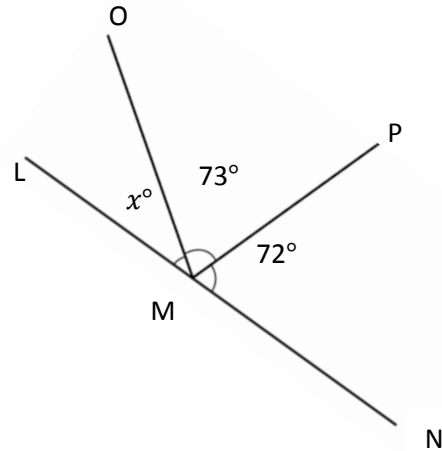

7. In the following figure, $DEFH$ is a rectangle. Without using a protractor, determine the measurement of $\angle GEF$. Write an equation that could be used to solve the problem.

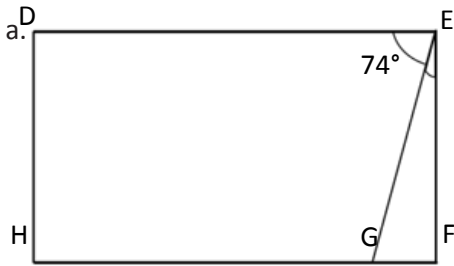

8. Complete the following directions in the space to the right.

- Draw 2 points: Q and R . Using a straightedge, draw \overline{QR} .
- Plot a point S somewhere between points Q and R .
- Plot a point T , which is not on \overline{QR} .
- Draw \overline{TS} .
- Find the measure of $\angle QST$ and $\angle RST$.
- Write an equation to show that the angles add to the measure of a straight angle.

Name _____

Date _____

Write an equation, and solve for the unknown angle measurements numerically.

1.

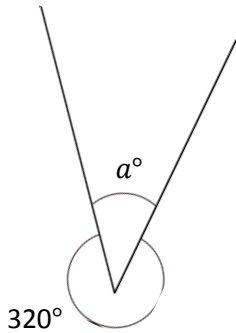

$$\underline{\hspace{1cm}}^\circ + 320^\circ = 360^\circ$$

$$a^\circ = \underline{\hspace{1cm}}^\circ$$

2.

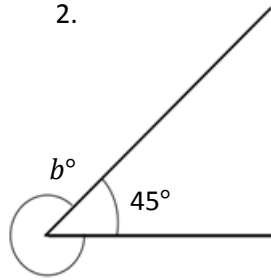

$$\underline{\hspace{1cm}}^\circ + \underline{\hspace{1cm}}^\circ = 360^\circ$$

$$b^\circ = \underline{\hspace{1cm}}^\circ$$

3.

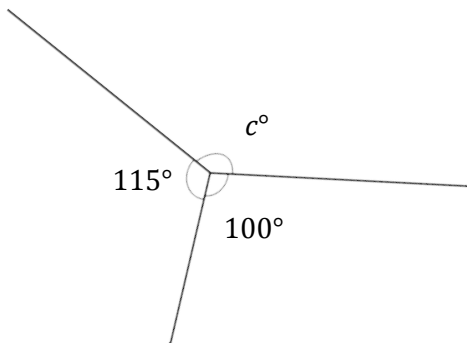

$$\underline{\hspace{1cm}}^\circ + \underline{\hspace{1cm}}^\circ + \underline{\hspace{1cm}}^\circ = \underline{\hspace{1cm}}^\circ$$

$$c^\circ = \underline{\hspace{1cm}}^\circ$$

4.

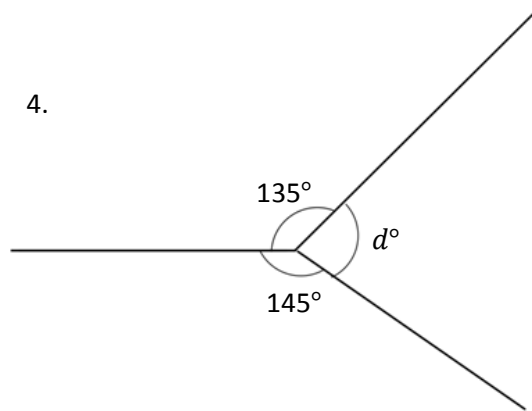

$$\underline{\hspace{1cm}}^\circ + \underline{\hspace{1cm}}^\circ + \underline{\hspace{1cm}}^\circ = \underline{\hspace{1cm}}^\circ$$

$$d^\circ = \underline{\hspace{1cm}}^\circ$$

Write an equation and solve for the unknown angles numerically.

5. O is the intersection of \overline{AB} and \overline{CD} .
 $\angle COB$ is 145° and $\angle AOC$ is 35° .

$e^\circ = \underline{\hspace{2cm}}$ $f^\circ = \underline{\hspace{2cm}}$

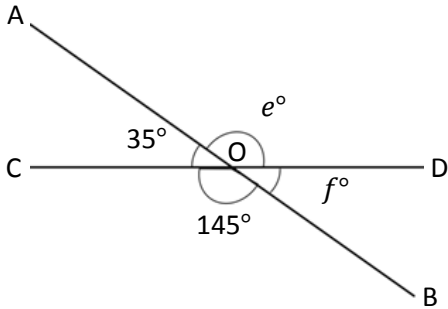

6. O is the intersection of \overline{QR} and \overline{ST} .
 $\angle QOS$ is 55° .

$g^\circ = \underline{\hspace{2cm}}$ $h^\circ = \underline{\hspace{2cm}}$ $i^\circ = \underline{\hspace{2cm}}$

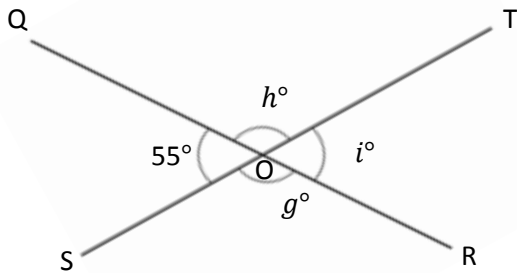

7. O is the intersection of \overline{UV} , \overline{WX} , and \overline{YO} .
 $\angle VOX$ is 46° .

$j^\circ = \underline{\hspace{2cm}}$ $k^\circ = \underline{\hspace{2cm}}$ $m^\circ = \underline{\hspace{2cm}}$

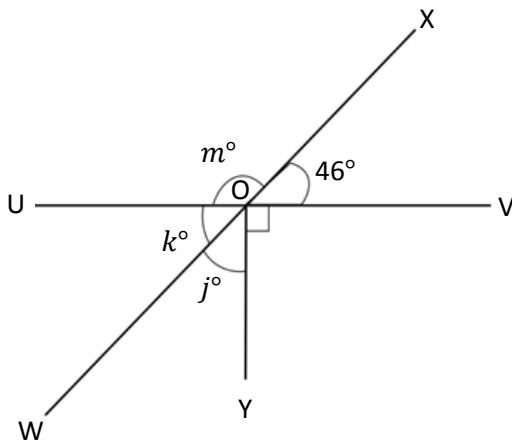

Name _____

Date _____

1. Circle the figures that have a correct line of symmetry drawn.

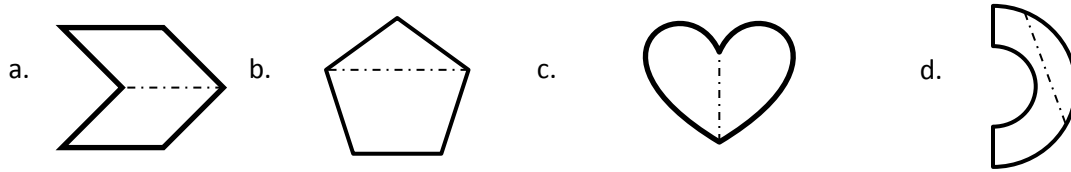

2. Find and draw all lines of symmetry for the following figures. Write the number of lines of symmetry that you found in the blank underneath the shape.

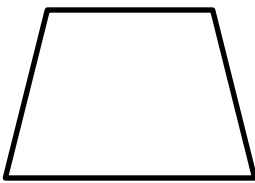

a. _____

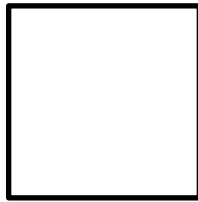

b. _____

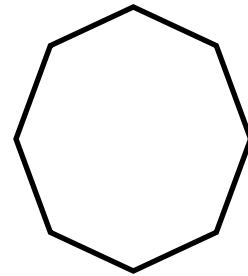

c. _____

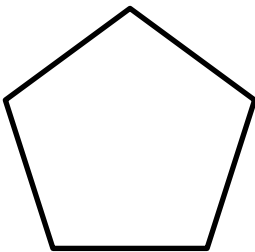

d. _____

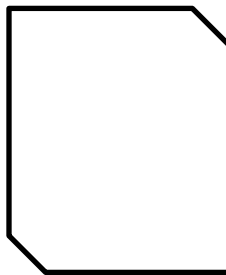

e. _____

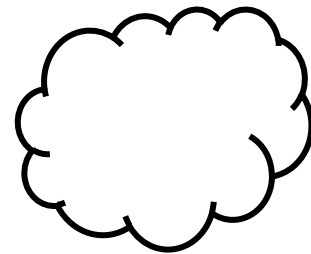

f. _____

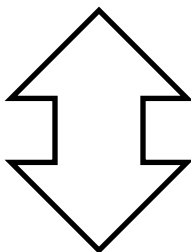

g. _____

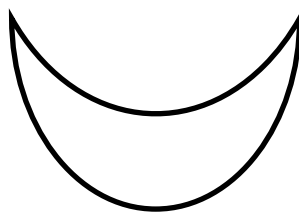

h. _____

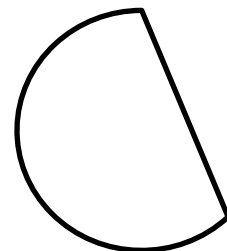

i. _____

3. Half of each figure below has been drawn. Use the line of symmetry, represented by the dashed line, to complete each figure.

a)

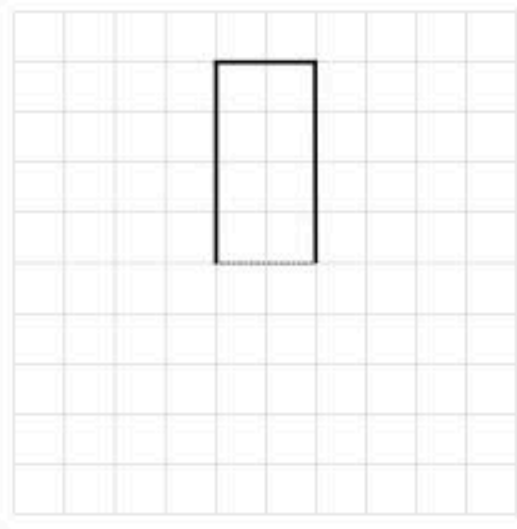

b)

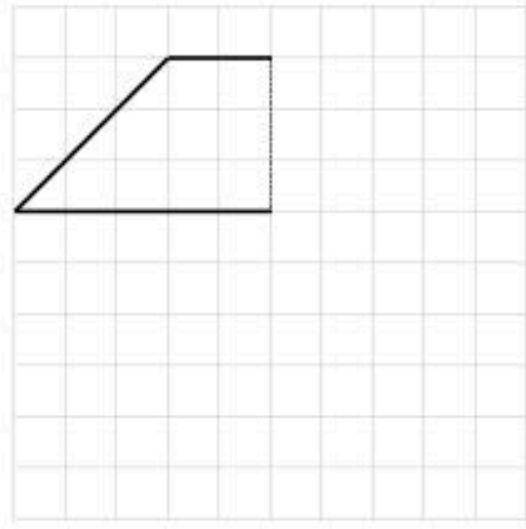

c)

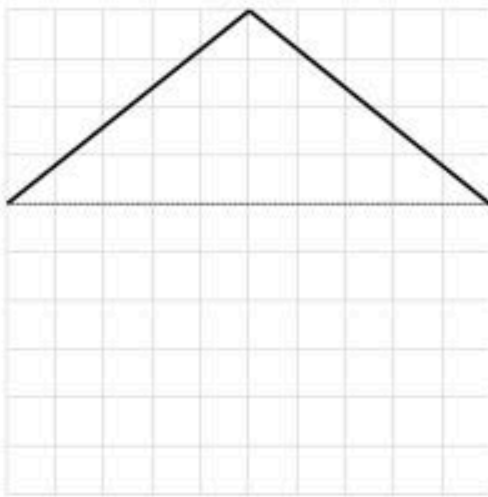

d)

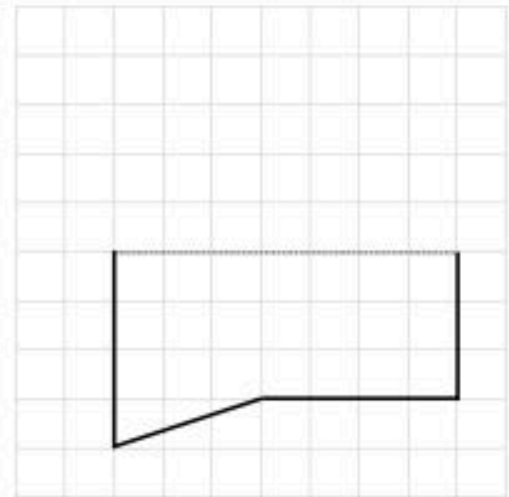

4. Is there another shape that has the same number of lines of symmetry as a circle? Explain.

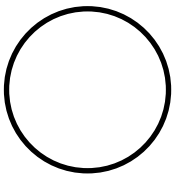

Name _____

Date _____

1. Classify each triangle by its side lengths and angle measurements. Circle the correct names.

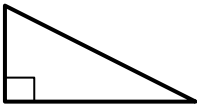
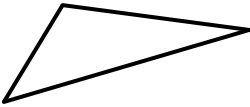
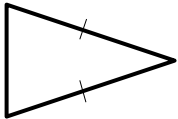
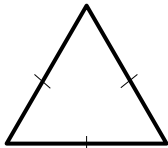
	Classify Using Side Lengths	Classify Using Angle Measurements
a. 	Equilateral Isosceles Scalene	Acute Right Obtuse
b. 	Equilateral Isosceles Scalene	Acute Right Obtuse
c. 	Equilateral Isosceles Scalene	Acute Right Obtuse
d. 	Equilateral Isosceles Scalene	Acute Right Obtuse

2. a. $\triangle ABC$ has one line of symmetry as shown. Is the measure of $\angle A$ greater than, less than, or equal to $\angle C$?

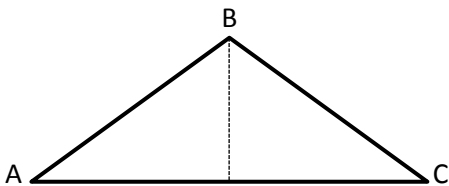

b. $\triangle DEF$ is scalene. What do you observe about its angles? Explain.

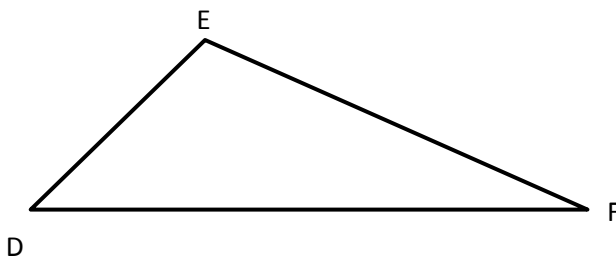

3. Use a ruler to connect points to form two other triangles. Use each point only once. None of the triangles may overlap. Two points will be unused. Name and classify the three triangles below.

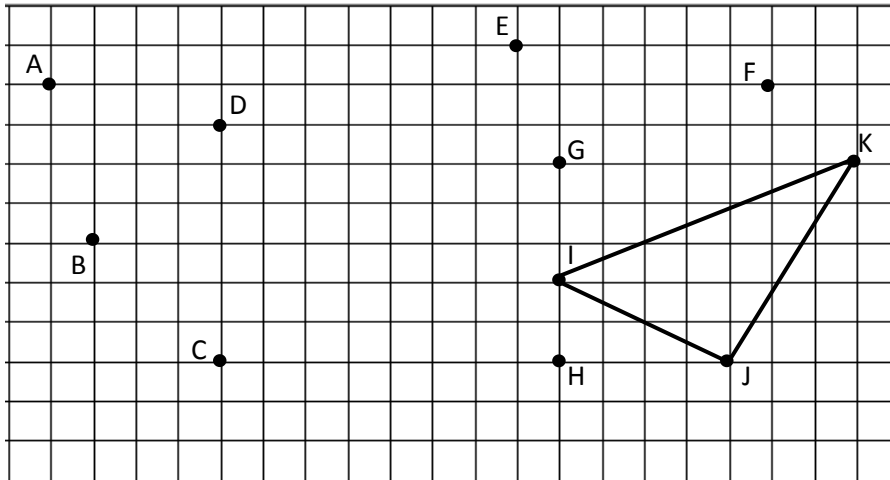

Name the Triangles Using Vertices	Classify by Side Length	Classify by Angle Measurement
$\triangle IJK$		

4. If the perimeter of an equilateral triangle is 15 cm, what is the length of each side?
5. Can a triangle have more than one obtuse angle? Explain.
6. Can a triangle have one obtuse angle and one right angle? Explain.

Name _____

Date _____

1. Draw triangles that fit the following classifications. Use a ruler and protractor. Label the side lengths and angles.

a. Right and isosceles

b. Right and scalene

c. Obtuse and isosceles

d. Acute and scalene

2. Draw all possible lines of symmetry in the triangles above. Explain why some of the triangles do not have lines of symmetry.

Are the following statements true or false? Explain.

3. $\triangle ABC$ is an isosceles triangle. \overline{AB} must be 2 cm. True or False?

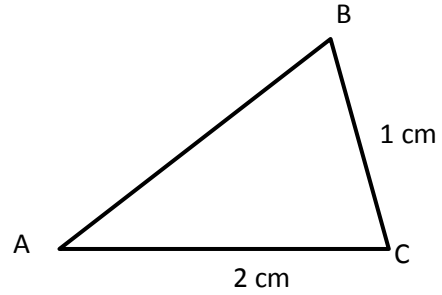

4. A triangle cannot have both an acute angle and a right angle. True or False?

5. $\triangle XYZ$ can be described as both equilateral and acute. True or False?

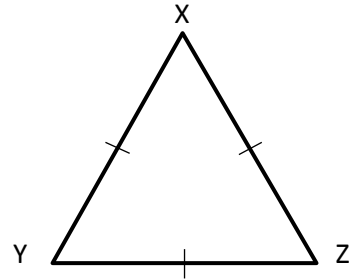

6. A right triangle is always scalene. True or False?

Extension: In $\triangle ABC$, $x^\circ = y^\circ$. True or False?

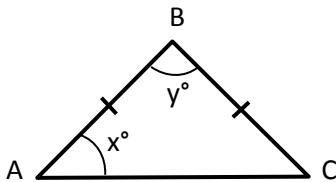

Name _____

Date _____

1. Use the word bank to name each shape, being as specific as possible.

Parallelogram	Trapezoid	Rectangle	Square
---------------	-----------	-----------	--------

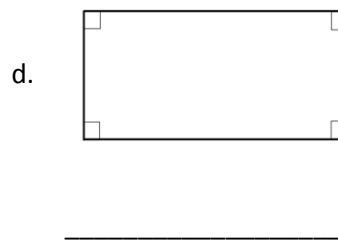
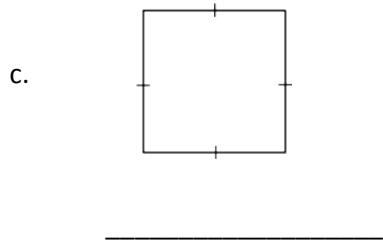
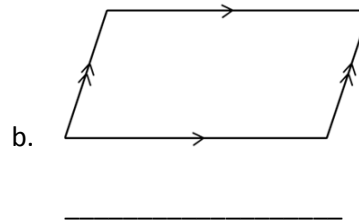
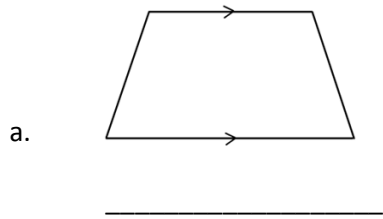

2. Explain the attribute that makes a square a special rectangle.

3. Explain the attribute that makes a rectangle a special parallelogram.

4. Explain the attribute that makes a parallelogram a special trapezoid.

5. Construct the following figures based on the given attributes. Give a name to each figure you construct. Be as specific as possible.
- a. A quadrilateral with four sides the same length and four right angles.
- b. A quadrilateral with two sets of parallel sides.
- c. A trapezoid with only one set of parallel sides.
- d. A parallelogram with four right angles.

Name _____

Date _____

Use the grid to construct the following. Name the figure you drew using one of the terms in the word box.

1. Construct a quadrilateral with only one set of parallel sides.

Which shape did you create?

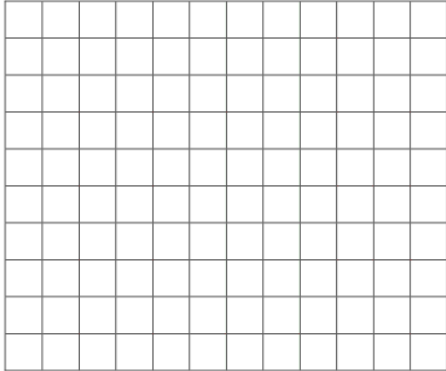

WORD BOX

Parallelogram

Trapezoid

Rectangle

Square

Rhombus

2. Construct a quadrilateral with one set of parallel sides and two right angles.

Which shape did you create?

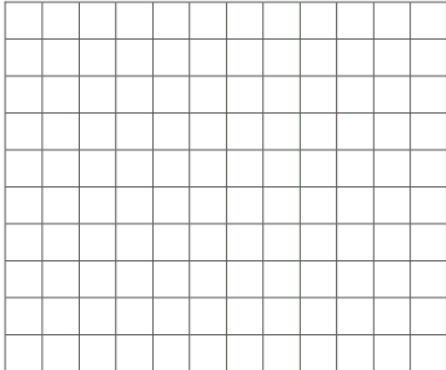

3. Construct a quadrilateral with two sets of parallel sides.

Which shape did you create?

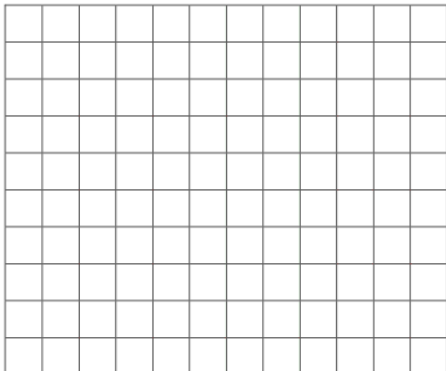

4. Construct a quadrilateral with all sides of equal length.
Which shape did you create?

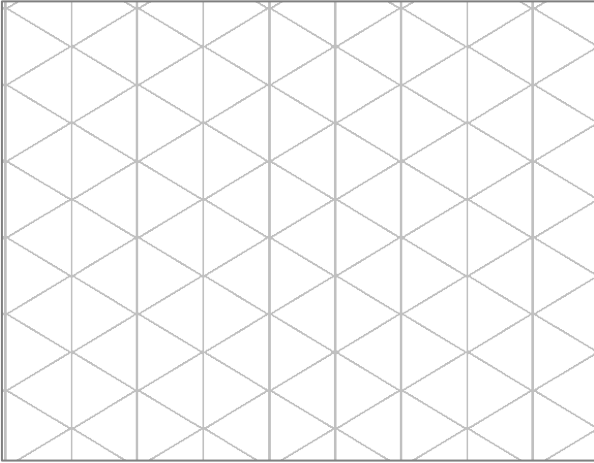

5. Construct a rectangle with all sides of equal length.
Which shape did you create?

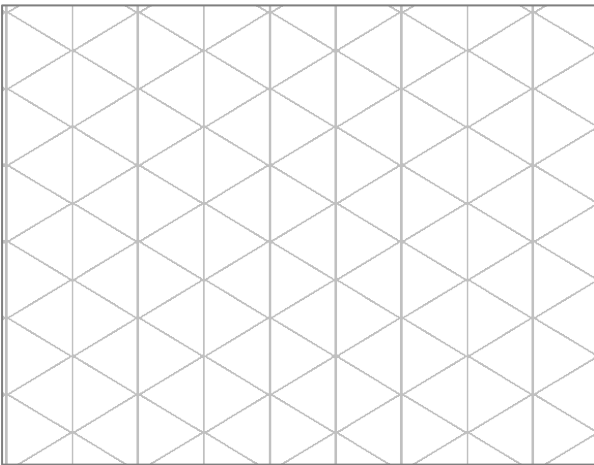

Name _____

Date _____

1. Fill in the blank to make the sentence true in both fraction form and decimal form.

a. $\frac{9}{10}$ cm + _____ cm = 1 cm

0.9 cm + _____ cm = 1.0 cm

b. $\frac{4}{10}$ cm + _____ cm = 1 cm

0.4 cm + _____ cm = 1.0 cm

2. Match each amount expressed in unit form to its fraction form and decimal form.

3 tenths

 $\frac{5}{10}$

0.8

8 tenths

 $\frac{8}{10}$

0.3

5 tenths

 $\frac{3}{10}$

0.5

Name _____

Date _____

1. For the length given below, draw a line segment to match. Express the measurement as an equivalent mixed number.

4.8 cm

2. Write the following in decimal form and as a mixed number. Shade the area model to match.

a. 3 ones and 7 tenths = _____ = _____

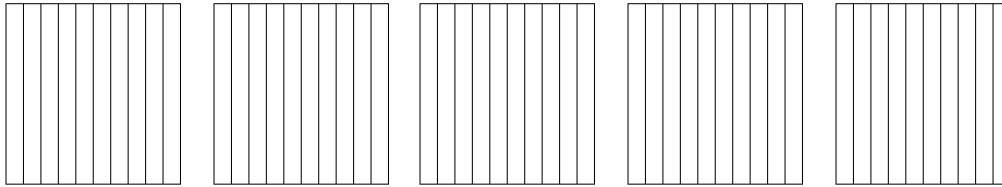

b. $\frac{24}{10}$ = _____ = _____

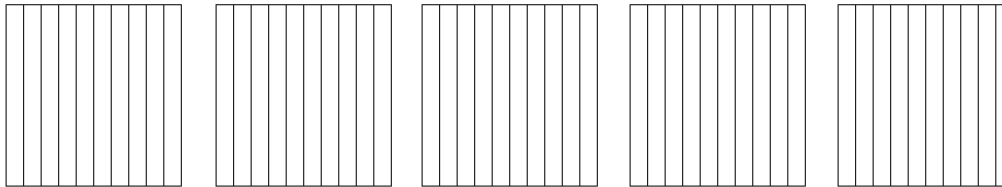

How much more is needed to get to 5? _____

Name _____

Date _____

1. Circle groups of tenths to make as many ones as possible.

<p>a. How many tenths in all?</p> <div style="text-align: center; margin: 10px 0;"> </div> <p>There are _____ tenths.</p>	<p>Write and draw the same number using ones and tenths.</p> <p>Decimal Form: _____</p> <p>How much more is needed to get to 2? _____</p>
---	--

2. Complete the chart.

Point	Number Line	Decimal Form	Mixed Number (ones and fraction form)	Expanded Form (fraction or decimal form)	How much to get to the next one?
a.			$12 \frac{9}{10}$		
b.		70.7			

Name _____

Date _____

1. Shade in the amount shown. Then, write the equivalent decimal.

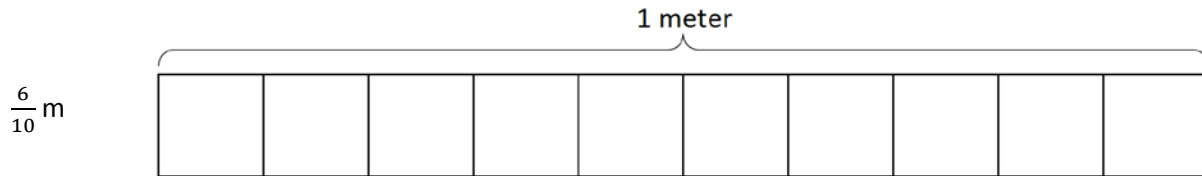

2. Draw a number bond, pulling out the tenths from the hundredths. Write the total as the equivalent decimal.

a. $\frac{62}{100}$ m

b. $\frac{27}{100}$

Name _____

Date _____

Use both tenths and hundredths number disks to represent each fraction. Write the equivalent decimal, and fill in the blanks to represent each in unit form.

1. $\frac{7}{100} = 0.\underline{\quad}$

____ hundredths

2. $\frac{34}{100} = 0.\underline{\quad}$

____ tenths ____ hundredths

Name _____

Date _____

Use any protractor to measure the angles, and then record the measurements in degrees.

1.

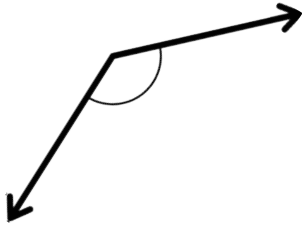

2.

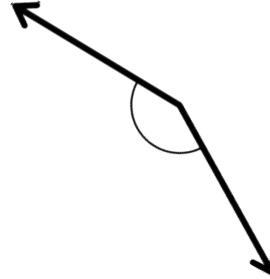

3.

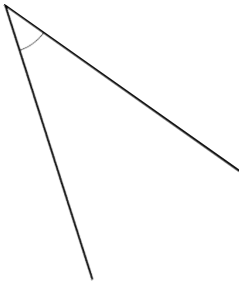

4.

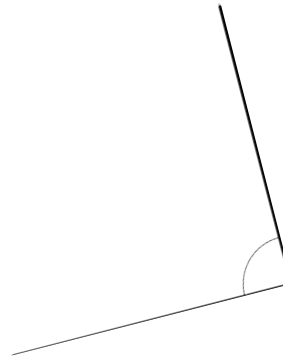

Name _____

Date _____

Construct angles that measure the given number of degrees. Draw an arc to indicate the angle that was measured.

1. 75° 2. 105° 3. 81° 4. 99°

Name _____

Date _____

- Marty was doing a handstand. Describe how many degrees his body will turn to be upright again.

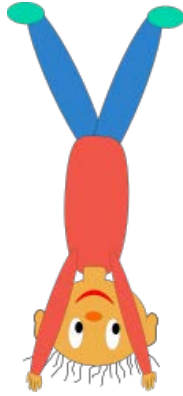

- Jeffrey started riding his bike at the ★. He travelled north for 3 blocks, then turned 90° to the right and rode for 2 blocks. In which direction was he headed? Sketch his route on the grid below. Each square unit represents 1 block.

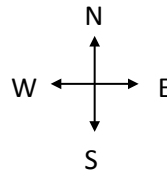
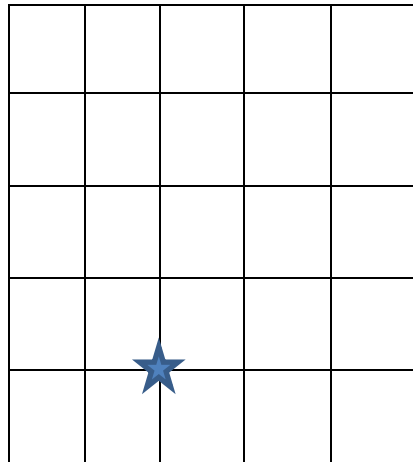

Name _____ Date _____

1. Describe and sketch two combinations of the blue rhombus pattern block that create a straight angle.

2. Describe and sketch two combinations of the green triangle and yellow hexagon pattern block that create a straight angle.

Name _____

Date _____

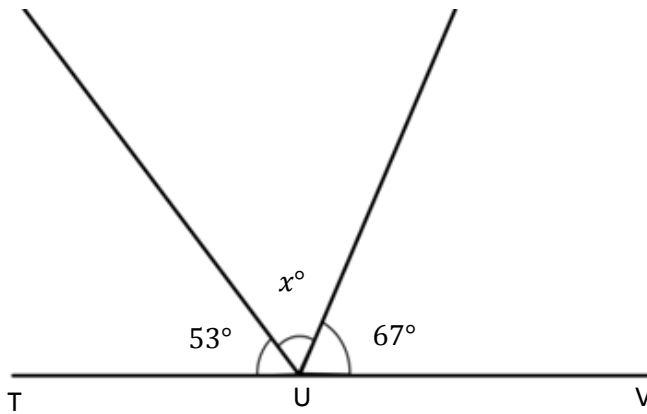
Write an equation and solve for x . $\angle TUV$ is a straight angle.

Equation: _____

 $x^\circ =$ _____

Name _____

Date _____

Write equations using variables to represent the unknown angle measurements. Find the unknown angle measurements numerically.

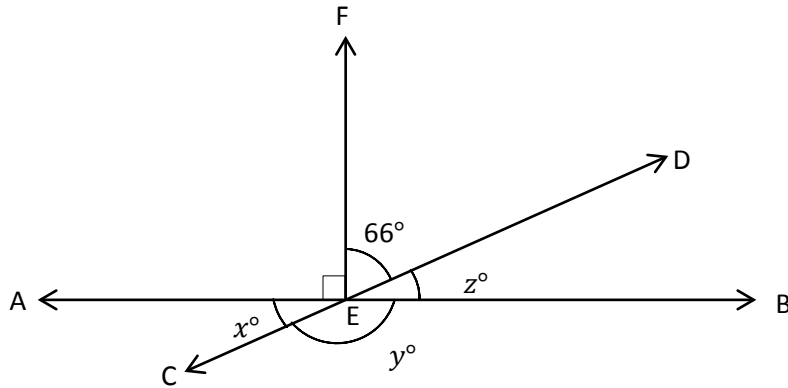

1. $x^\circ =$

2. $y^\circ =$

3. $z^\circ =$

Name _____

Date _____

1. Is the line drawn a line of symmetry? Circle your choice.

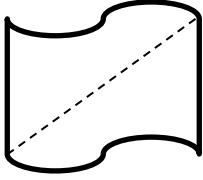

Yes No

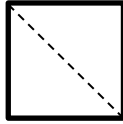

Yes No

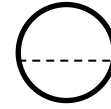

Yes No

2. Draw as many lines of symmetry as you can find in the figure below.

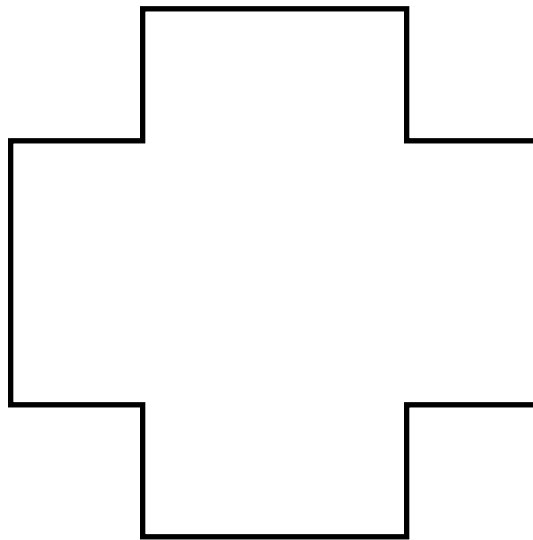

Name _____

Date _____

Use appropriate tools to solve the following problems.

1. The triangles below have been classified by shared attributes (side length or angle type). Use the words *acute*, *right*, *obtuse*, *scalene*, *isosceles*, or *equilateral* to label the headings to identify the way the triangles have been sorted.

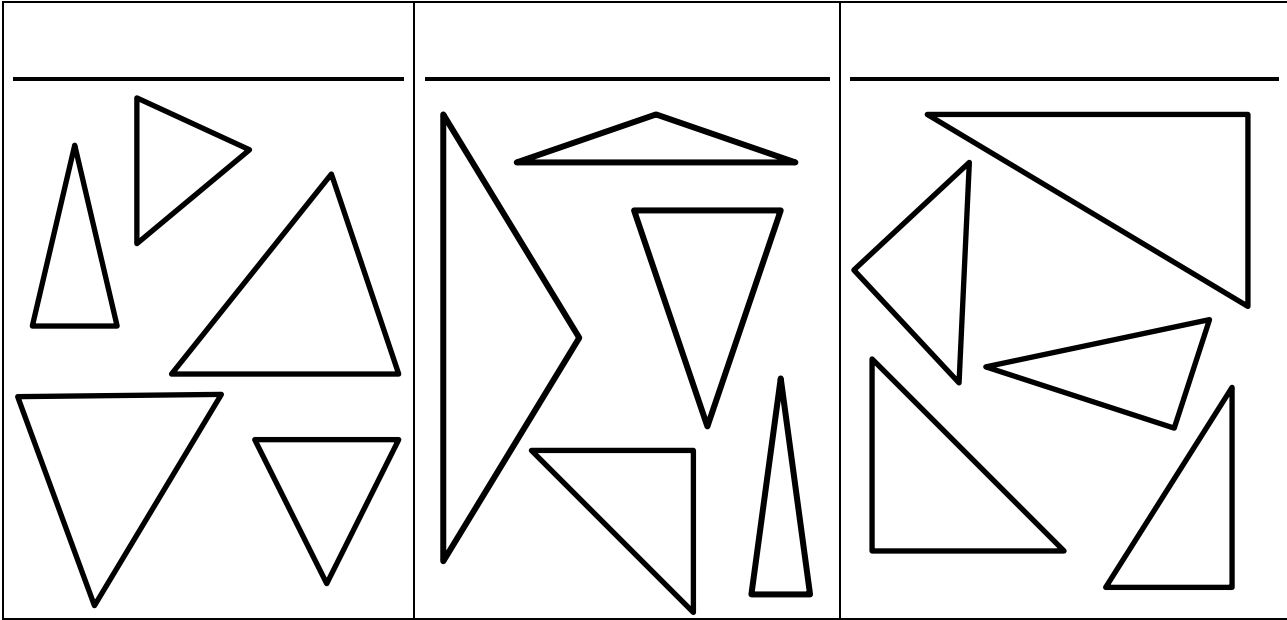

2. Draw lines to identify each triangle according to angle type *and* side length.



Acute

Obtuse

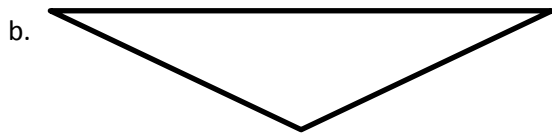

Right

Isosceles

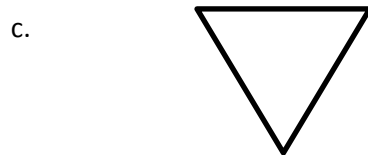

Equilateral

Scalene

3. Identify and draw any lines of symmetry in the triangles in Problem 2.

Name _____ Date _____

1. Draw an obtuse isosceles triangle, and then draw any lines of symmetry if they exist.

2. Draw a right scalene triangle, and then draw any lines of symmetry if they exist.

3. Every triangle has at least ____ acute angles.

Name _____

Date _____

1. In the space below, draw a parallelogram.

2. Explain why a rectangle is a special parallelogram.

Name _____

Date _____

1. Construct a parallelogram that does not have any right angles on a rectangular grid.

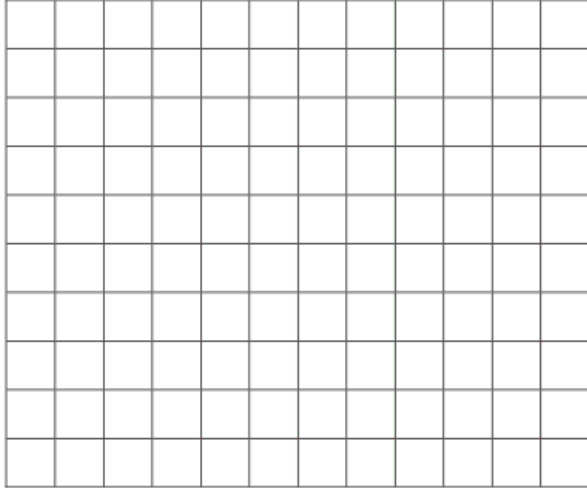

2. Construct a rectangle on a triangular grid.

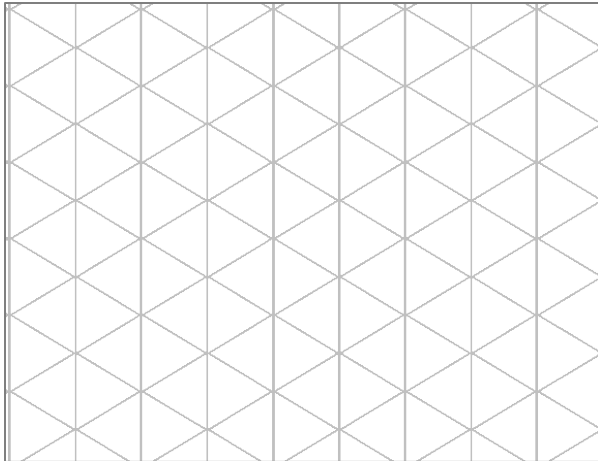

Number Correct: _____

A

Divide by 10

1.	$20 \div 10 =$	
2.	$30 \div 10 =$	
3.	$40 \div 10 =$	
4.	$80 \div 10 =$	
5.	$50 \div 10 =$	
6.	$90 \div 10 =$	
7.	$70 \div 10 =$	
8.	$60 \div 10 =$	
9.	$10 \div 10 =$	
10.	$100 \div 10 =$	
11.	$20 \div 10 =$	
12.	$120 \div 10 =$	
13.	$50 \div 10 =$	
14.	$150 \div 10 =$	
15.	$80 \div 10 =$	
16.	$180 \div 10 =$	
17.	$280 \div 10 =$	
18.	$380 \div 10 =$	
19.	$680 \div 10 =$	
20.	$640 \div 10 =$	
21.	$870 \div 10 =$	
22.	$430 \div 10 =$	

23.	$50 \div 10 =$	
24.	$850 \div 10 =$	
25.	$1,850 \div 10 =$	
26.	$70 \div 10 =$	
27.	$270 \div 10 =$	
28.	$4,270 \div 10 =$	
29.	$90 \div 10 =$	
30.	$590 \div 10 =$	
31.	$7,590 \div 10 =$	
32.	$120 \div 10 =$	
33.	$1,200 \div 10 =$	
34.	$2,000 \div 10 =$	
35.	$240 \div 10 =$	
36.	$2,400 \div 10 =$	
37.	$4,000 \div 10 =$	
38.	$690 \div 10 =$	
39.	$6,900 \div 10 =$	
40.	$9,000 \div 10 =$	
41.	$940 \div 10 =$	
42.	$5,280 \div 10 =$	
43.	$6,700 \div 10 =$	
44.	$7,000 \div 10 =$	

B

Number Correct: _____

Improvement: _____

Divide by 10

1.	$10 \div 10 =$	
2.	$20 \div 10 =$	
3.	$30 \div 10 =$	
4.	$70 \div 10 =$	
5.	$40 \div 10 =$	
6.	$80 \div 10 =$	
7.	$60 \div 10 =$	
8.	$50 \div 10 =$	
9.	$90 \div 10 =$	
10.	$100 \div 10 =$	
11.	$30 \div 10 =$	
12.	$130 \div 10 =$	
13.	$60 \div 10 =$	
14.	$160 \div 10 =$	
15.	$90 \div 10 =$	
16.	$190 \div 10 =$	
17.	$290 \div 10 =$	
18.	$390 \div 10 =$	
19.	$690 \div 10 =$	
20.	$650 \div 10 =$	
21.	$860 \div 10 =$	
22.	$420 \div 10 =$	

23.	$40 \div 10 =$	
24.	$840 \div 10 =$	
25.	$1,840 \div 10 =$	
26.	$80 \div 10 =$	
27.	$80 \div 10 =$	
28.	$4,280 \div 10 =$	
29.	$60 \div 10 =$	
30.	$560 \div 10 =$	
31.	$7,560 \div 10 =$	
32.	$130 \div 10 =$	
33.	$1,300 \div 10 =$	
34.	$3,000 \div 10 =$	
35.	$250 \div 10 =$	
36.	$2,500 \div 10 =$	
37.	$5,000 \div 10 =$	
38.	$740 \div 10 =$	
39.	$7,400 \div 10 =$	
40.	$4,000 \div 10 =$	
41.	$910 \div 10 =$	
42.	$5,820 \div 10 =$	
43.	$7,600 \div 10 =$	
44.	$6,000 \div 10 =$	

Number Correct: _____

A

Write Fractions and Decimals

1.	$\frac{2}{10} =$.
2.	$\frac{3}{10} =$.
3.	$\frac{4}{10} =$.
4.	$\frac{8}{10} =$.
5.	$\frac{6}{10} =$.
6.	$0.1 =$	$\frac{\quad}{10}$
7.	$0.2 =$	$\frac{\quad}{10}$
8.	$0.3 =$	$\frac{\quad}{10}$
9.	$0.7 =$	$\frac{\quad}{10}$
10.	$0.5 =$	$\frac{\quad}{10}$
11.	$\frac{5}{10} =$.
12.	$0.8 =$	$\frac{\quad}{10}$
13.	$\frac{7}{10} =$.
14.	$0.4 =$	$\frac{\quad}{10}$
15.	$\frac{9}{10} =$.
16.	$\frac{10}{10} =$.
17.	$\frac{11}{10} =$.
18.	$\frac{12}{10} =$.
19.	$\frac{15}{10} =$.
20.	$\frac{25}{10} =$.
21.	$\frac{45}{10} =$.
22.	$\frac{38}{10} =$.

23.	$1 =$	$\frac{\quad}{10}$
24.	$2 =$	$\frac{\quad}{10}$
25.	$5 =$	$\frac{\quad}{10}$
26.	$4 =$	$\frac{\quad}{10}$
27.	$4.1 =$	$\frac{\quad}{10}$
28.	$4.2 =$	$\frac{\quad}{10}$
29.	$4.6 =$	$\frac{\quad}{10}$
30.	$2.6 =$	$\frac{\quad}{10}$
31.	$3.6 =$	$\frac{\quad}{10}$
32.	$3.4 =$	$\frac{\quad}{10}$
33.	$2.3 =$	$\frac{\quad}{10}$
34.	$4\frac{3}{10} =$.
35.	$\frac{20}{10} =$.
36.	$1.8 =$	$\frac{\quad}{10}$
37.	$3\frac{4}{10} =$.
38.	$\frac{50}{10} =$.
39.	$4.7 =$	$\frac{\quad}{10}$
40.	$2\frac{8}{10} =$.
41.	$\frac{30}{10} =$.
42.	$3.2 =$	$\frac{\quad}{10}$
43.	$\frac{20}{10} =$.
44.	$2.1 =$	$\frac{\quad}{10}$

B

Number Correct: _____

Improvement: _____

Write Fractions and Decimals

1.	$\frac{1}{10} =$.
2.	$\frac{2}{10} =$.
3.	$\frac{3}{10} =$.
4.	$\frac{7}{10} =$.
5.	$\frac{5}{10} =$.
6.	0.2 =	$\frac{\quad}{10}$
7.	0.3 =	$\frac{\quad}{10}$
8.	0.4 =	$\frac{\quad}{10}$
9.	0.8 =	$\frac{\quad}{10}$
10.	0.6 =	$\frac{\quad}{10}$
11.	$\frac{4}{10} =$.
12.	0.9 =	$\frac{\quad}{10}$
13.	$\frac{6}{10} =$.
14.	0.5 =	$\frac{\quad}{10}$
15.	$\frac{9}{10} =$.
16.	$\frac{10}{10} =$.
17.	$\frac{11}{10} =$.
18.	$\frac{12}{10} =$.
19.	$\frac{17}{10} =$.
20.	$\frac{27}{10} =$.
21.	$\frac{47}{10} =$.
22.	$\frac{34}{10} =$.

23.	1 =	$\frac{\quad}{10}$
24.	2 =	$\frac{\quad}{10}$
25.	4 =	$\frac{\quad}{10}$
26.	3 =	$\frac{\quad}{10}$
27.	3.1 =	$\frac{\quad}{10}$
28.	3.2 =	$\frac{\quad}{10}$
29.	3.6 =	$\frac{\quad}{10}$
30.	1.6 =	$\frac{\quad}{10}$
31.	2.6 =	$\frac{\quad}{10}$
32.	4.2 =	$\frac{\quad}{10}$
33.	2.5 =	$\frac{\quad}{10}$
34.	$3\frac{4}{10} =$.
35.	$\frac{50}{10} =$.
36.	1.7 =	$\frac{\quad}{10}$
37.	$4\frac{3}{10} =$.
38.	$\frac{20}{10} =$.
39.	4.6 =	$\frac{\quad}{10}$
40.	$2\frac{4}{10} =$.
41.	$\frac{40}{10} =$.
42.	2.3 =	$\frac{\quad}{10}$
43.	$\frac{30}{10} =$.
44.	4.1 =	$\frac{\quad}{10}$

